

## DCWB\_YD-30W Series



CE Report RoHS



### FEATURES

- Wide input voltage range (4:1)
- High efficiency up to 87%
- No-load power consumption as low as 0.12W
- Isolation voltage :1.6K VDC
- Input under-voltage protection, output short circuit, over-current protection
- Operating temperature range: -40°C To +85°C
- 3 Years Warranty

### DESCRIPTION

DC-DC module power supply, Wide voltage input, Power 6W, Isolated, Regulated, Single output, DIP packaging.

### MODEL NUMBERING

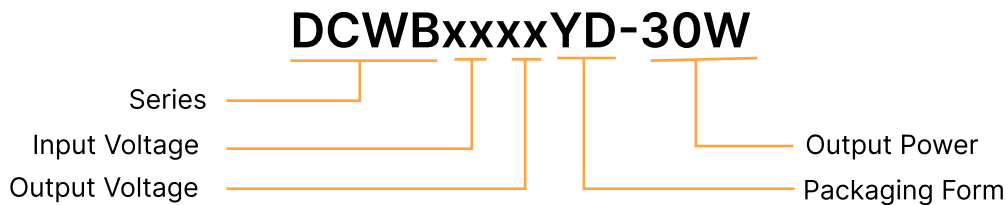

### SELECTION GUIDE

Product Model	Input Voltage Standard Value(range)	Output Voltage	Output Current (mA) (Max./Min.)	Efficiency % (Min./Typ.)	Maximum Capacitive load ( $\mu$ F)
DCWB2403YD-30W	24VDC (9-36)	3.3	6000/0	84/86	10000
DCWB2405YD-30W		5	6000/0	86/88	10000
DCWB2409YD-30W		9	3333/0	86/88	4700
DCWB2412YD-30W		12	2500/0	88/90	1500
DCWB2415YD-30W		15	2000/0	88/90	1000
DCWB2424YD-30W		24	1250/0	88/90	750

Product Model	Input Voltage Standard Value(range)	Output Voltage	Output Current (mA) (Max./Min.)	Efficiency % (Min./Typ.)	Maximum capacitive load ( $\mu$ F)
DCWB4803YD-30W	48VDC (18-75)	3.3	6000/0	84/86	10000
DCWB4805YD-30W		5	6000/0	86/88	10000
DCWB4809YD-30W		9	3333/0	86/88	4700
DCWB4812YD-30W		12	2500/0	88/90	1500
DCWB4815YD-30W		15	2000/0	88/90	1000
DCWB4824YD-30W		24	1250/0	88/90	750

## INPUT CHARACTERISTICS

Parameter	Operating Conditions	Min.	Typ.	Max.	Units
Input Current (full load / no-load)		--	710/8	735/15	mA
Reflected Ripple Current		--	40	--	mA
Surge Voltage (1sec. max.)	Nominal input voltage	-0.7	--	100	VDC
Start-up Voltage		--	--	18	VDC
Input under-voltage protection		12	15.5	--	VDC
Start-up Time	Nominal input voltage & constant resistance load	--	10	--	ms
Input Filter	12VDC nominal input voltage	Capacitance filter			
Ctrl*	Module on	Ctrl pin open or pulled high (TTL 3.5-12VDC)			
	Module off	Ctrl pin pulled low to GND(0-1.2VDC)			
	Input current when off	--	2	7	mA

Note: \*The Ctrl pin voltage is referenced to input GND.

Remarks: This product does not support hot plug

## OUTPUT CHARACTERISTICS

Parameter	Operating Conditions		Min.	Typ.	Max.	Units
Output Voltage Accuracy	5%-100% load		--	±1	±3	%
Linear Regulation	Input voltage variation from low to high at full load		--	±0.2	±0.5	%
Load Regulation	5%-100% load		--	±0.5	±1	%
Transient Recovery Time	25% load step change, nominal input voltage		--	250	500	µs
Transient Response Deviation	25% load step change, input voltage range	3.3V, 5V,output	--	±3	±8	%
		Others	--	±3	±5	%
Temperature Coefficient	Full load		--	--	±0.03	%/°C
Ripple & Noise *	20MHz bandwidth, nominal input voltage, 5%-100% load	5V/12V/15V output	--	60	120	mVp-p
		24V output	--	60	150	mVp-p
Trim	Input voltage range		90	--	110	%Vo
Over-voltage Protection			110	--	160	%Vo
Over-current Protection			110	170	260	%Io
Short circuit Protection			Continuous, self-recovery			

Note: \*Ripple & Noise at < 5% load is 300mV max. The "parallel cable" method is used for Ripple and Noise test, please refer to DC-DC Converter ApplicationNotes for specific information.

## GENERAL CHARACTERISTIC

Parameter	Operating Conditions	Min.	Typ.	Max.	Units
Isolation	Input-output Electric Strength Test for 1 minute with a leakage current of 1mA max.	1500	--	--	VDC
Insulation Resistance	Input-output resistance at 500VDC	1000	--	--	MΩ
Isolation Capacitance	Input-output capacitance at 100KHz/0.1V	--	2000	--	pF

Parameter	Operating Conditions	Min.	Typ.	Max.	Units
Operating Temperature	See Fig. 1	-40	--	+85	°C
Storage Humidity	Without condensation	5	--	95	%RH
Storage Temperature		-55	--	+125	°C
Pin Soldering Resistance Temperature	Soldering spot is 1.5mm away from case for 10 seconds	--	--	+300	°C
Vibration		10-150Hz,5G, 0.75mm. along X, Y & Z			
Switching Frequency *	PWM mode	--	270	--	KHz
MTBF	MIL-HDBK-217F@25°C	1000	--	--	Khours

Note: \*Switching frequency is measured at full load. The module reduces the switching frequency for light load (below 50%) efficiency improvement.

## PHYSICAL CHARACTERISTICS

Parameter	Conditions
Case Material	Aluminum alloy
Overall dimensions	25.40 × 25.40 × 11.70 mm
Weight	18.4g
Cooling Method	Free air convection

## EMC CHARACTERISTICS

Parameter	Category	Content	
EMI	CE	CISPR32/EN55032	CLASS B (see Fig.3-② for recommended circuit)
	RE	CISPR32/EN55032	CLASS B (see Fig.3-② for recommended circuit)
EMC	ESD	IEC/EN61000-4-2	Contact ±4KV perf. CriteriaB
	RS	IEC/EN61000-4-3	10V/m perf. CriteriaA
	EFT	IEC/EN61000-4-4	±2KV (see Fig.3-① for recommended circuit) perf. CriteriaB
	Surge	IEC/EN61000-4-5	line to line ±2KV (see Fig.3-① for recommended circuit) perf. CriteriaB
	CS	IEC/EN61000-4-6	3 Vr.m.s perf. CriteriaA

CIRCUIT DESIGN AND APPLICATION

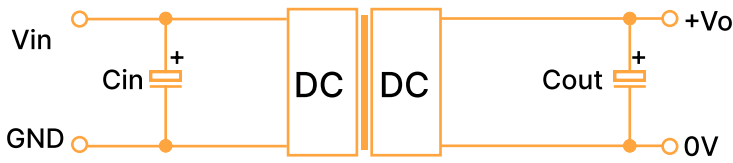

Figure 1: Application circuit

Table 1: Recommended Capacitive Load Values

Vout (VDC)	Cin (μF)	Cout (μF)
5, 15	100	100
24		47

2. EMC compliance circuit

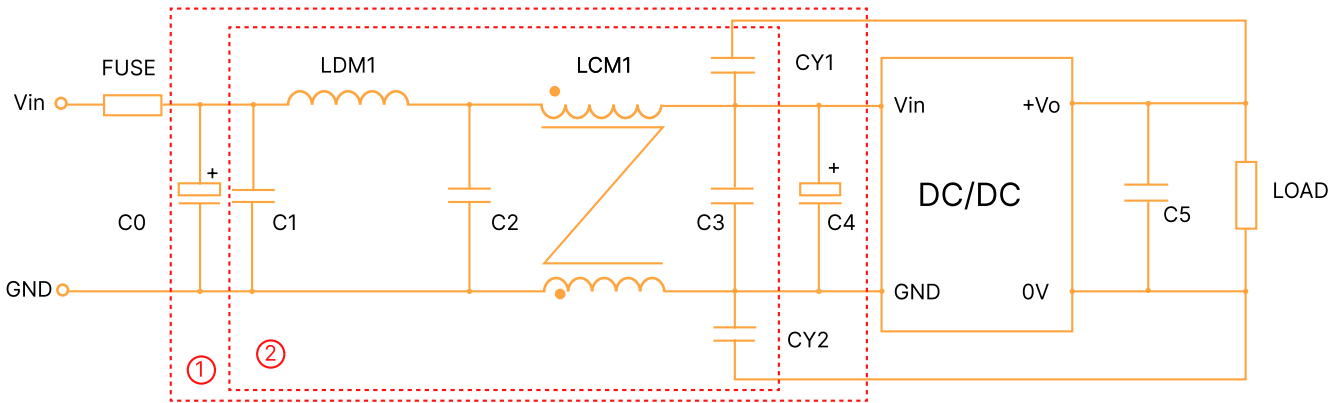

Figure 3

Notes: Part ① in the Fig. 3 is used for EMC test and part ② for EMI filtering; selected based on needs.

Fig. 3 Parameter description

Model	Vin:24V
FUSE	Choose according to actual input current
C0, C4	470μF/100V
C1	10μF/100V
LDM1	22uH/3A
C2	22uF/100V
LCM1	10mH, recommended to use
C3	22uF/100V
C5	Refer to the Cout in Fig.2
CY1, CY2	1nF/2KV

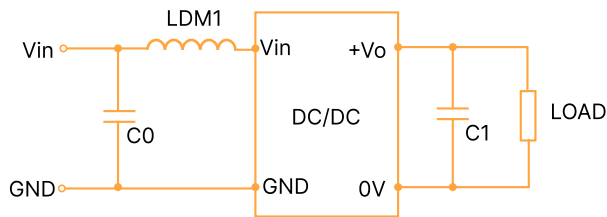
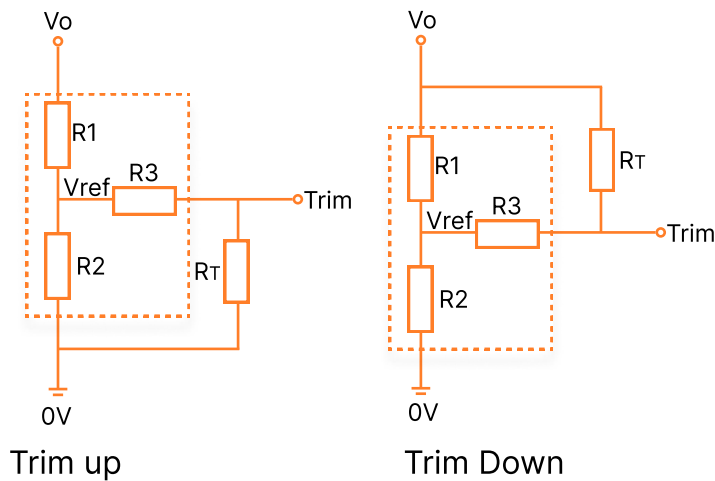

Figure 4

Parameter description:

Model	Vin:48V
C0	4.7μF/100V
LDM1	22uH/3A
C1	Refer to the Cout in Fig.2

### TRIM FUNCTION FOR OUTPUT VOLTAGE ADJUSTMENT (OPEN IF UNUSED)



The Calculation formula for trip resistance

$$\text{Trim up: } R_T \frac{aR_2}{R_2-a} - R_3 \quad a = \frac{V_{ref}}{V_o - V_{ref}} R_1$$

$$\text{Trim down: } R_T \frac{aR_1}{R_1-a} - R_3 \quad a = \frac{V_o - V_{ref}}{V_{ref}} R_2$$

$R_T$  is Trim resistance  
 $a$  is a self-defined parameter, with no real meaning.

TRIM resistor connection (dashed line shows internal resistor network)

Vout(V)	R1(KΩ)	R2(KΩ)	R3(KΩ)	Vref(V)
3.3	4.772	2.87	12.4	1.25
5	2.883	2.87	10	2.5
09	7.500	2.87	15	2.5
12	11.000	2.87	15	2.5
15	14.494	2.87	15	2.5
24	24.872	2.87	17.8	2.5

### PRODUCT CHARACTERISTIC CURVE

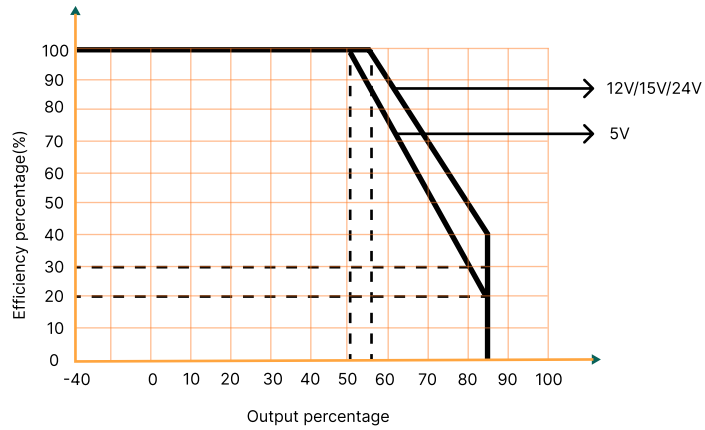

Figure 4: Temperature Derating Curve

### OVERALL DIMENSIONS AND PIN FUNCTIONS

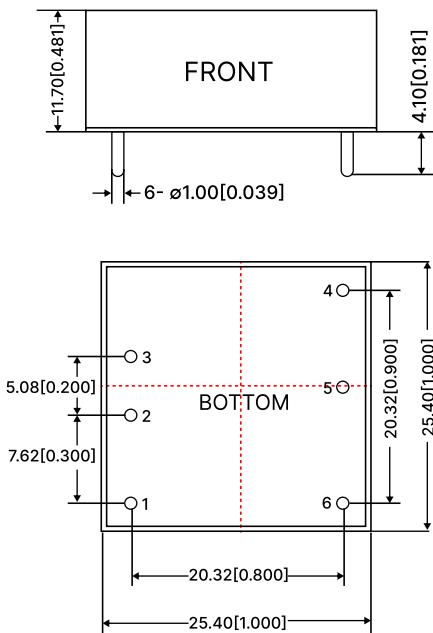
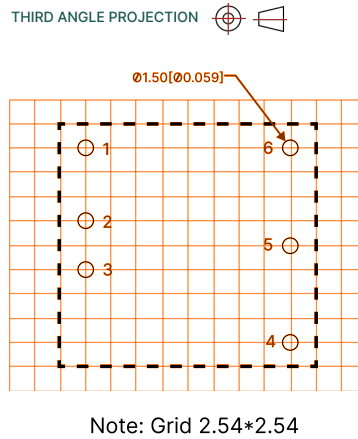

Figure 7: Overall dimensions



Unit: mm[inch]  
 Pin diameter tolerances:  $\pm 0.10$   
 General tolerances:  $\pm 0.50$

Table 3: Pin Function Table

Pin	Function
1	Ctrl
2	GND
3	Vin
4	+Vo
5	Trim
6	0V

\*NC cannot be connected to any external circuits

PACKAGING METHOD

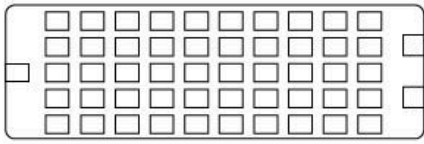

50 Pieces/Tube

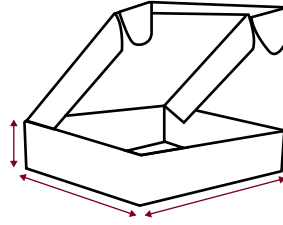

100 Pieces/Inner box

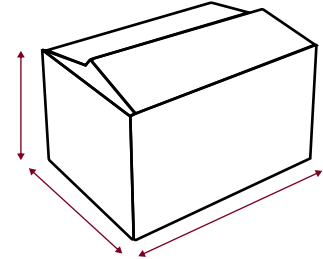

500 Pieces/Outer box

NOTES & INSTRUCTIONS

- 1.The input voltage shall not exceed the specified range value, otherwise permanent and unrecoverable damage maybe caused;
2. Unless otherwise specified,the parameters in this manual are measured at 25 °C,40%~75% humidity, input nominal voltage and output pure resistance mode under full load;
- 3.All index test methods are based on the company's enterprise standards.
- 4.The copyright and the final interpretation right of the product belong to HENXV.