

DCWA_YD-6W Series



CE Report

RoHS



FEATURES

- Wide voltage range input (2:1)
- Working temperature range: -40 °C to +85 °C
- Up to 85% efficiency
- Standby power consumption: 0.12W
- Output short circuit, overcurrent, overload protection
- 3 Years Warranty

DESCRIPTION

DC-DC module power supply, Wide voltage input, Power 6W, Isolated, Regulated, Positive and negative dual output, DIP packaging.

MODEL NUMBERING

DCWAxxxxYD-6W



SELECTION GUIDE

Product Model	Input Voltage Standard Value(range)	Output Voltage	Output Current (mA) (Max./Min.)	Efficiency % (Min./Typ.)	Maximum capacitive load (μ F)
DCWA2405YD-06W	24VDC (9-36)	\pm 5	\pm 600/ \pm 30	81/83	470
DCWA2412YD-06W		\pm 12	\pm 250/ \pm 12	85/87	100
DCWA2415YD-06W		\pm 15	\pm 200/ \pm 10	86/88	100
DCWA2424YD-06W		\pm 24	\pm 125/ \pm 6	86/88	100

Product Model	Input Voltage Standard Value(range)	Output Voltage	Output Current (mA) (Max./Min.)	Efficiency % (Min./Typ.)	Maximum capacitive load (μ F)
DCWA4805YD-06W	48VDC (18-75)	± 5	$\pm 600/\pm 30$	81/83	470
DCWA4812YD-06W		± 12	$\pm 250/\pm 12$	85/87	100
DCWA4815YD-06W		± 15	$\pm 200/\pm 10$	86/88	100
DCWA4824YD-06W		± 24	$\pm 125/\pm 6$	86/88	100

INPUT CHARACTERISTICS

Parameter	Operating Conditions	Min.	Typ.	Max.	Units
Input Current (full load / no-load)	24VDC Input	--	316/5	--	mA
	48VDC Input	--	160/4	--	mA
Reflected Ripple Current	24VDC Input	--	20	--	mA
	48VDC Input	--	20	--	mA
Input Impulse Voltage (1sec. max.)	24VDC Input	-0.7	--	50	VDC
	48VDC Input	-0.7	--	100	VDC
Starting Voltage	24VDC Input	--	--	09	VDC
	48VDC Input	--	--	18	VDC
under-voltage turn-off	24VDC Input	5.5	6.5	--	VDC
	48VDC Input	14.0	15.5	--	VDC
Input Fiiter		Input Fiiter PI filter			

Remarks: This product does not support hot plug

OUTPUT CHARACTERISTICS

Parameter	Operating Conditions		Min.	Typ.	Max.	Units
Output Voltage Accuracy			--	±1	±3	%
Balance of Output Voltage	Dual output, balanced load		--	±0.5	±1.5	%
Line Voltage Regulation	Full load, the Input voltage Is from low voltage to high voltage		--	±0.2	±0.5	%
Load Regulation	5%-100% load		--	±0.5	±1	%
Cross Regulation	Dual output, main circuit with 50% load, auxillary circuit with 10%-100% load		--	--	±5	%
Transient Recovery Time			--	300	500	μs
Transient Response Deviation	25% load step change	3.3V, 5V, ±5V output	--	±5	±8	%
		Others	--	±3	±5	%
Temperature Drift Coefficient	Full load		--	--	±0.03	%/°C
Ripple & Noise*	20MHz bandwidth		--	60	85	mVp-p
Output Over-voltage Protection	Input voltage range		110	--	160	%Vo
Output Over-current Protection			110	140	190	%Vo
Output Short circuit Protection			Continuous, self-recovery			

Note:*Parallel line test method is adopted to test ripple and noise, please see DC-DC Converter Application Notes for specific operation methods

GENERAL CHARACTERISTIC

Parameter	Operating Conditions	Min.	Typ.	Max.	Units
Insulation Voltage	Input-output, with the test time of 1 minute and the leak current lower than 1mA	1500	--	--	VDC
Insulation Resistance	Input-output, isolation voltage 500VDC	1000	--	--	MΩ
Isolation Capacitance	Input-output, 100kHz/0.1V	--	1000	--	pF
Operating Temperature	Derating If the temperature Is ≥71°C (see Flg. 1)	-40	--	85	°C

Parameter	Conditions	Min.	Typ.	Max.	Units
Storage Humidity	Without condensation	5	--	95	%
Storage Temperature		-55	250	--	°C
Max. Operating Temperature for Casing	Within the operating temperature curve	--	--	--	°C
Lead Temperature	Welding spot is 1.5mm away from the casing, 10 seconds	--	--	--	°C
Vibration		10-55Hz, 10G, 30 Min. along X, Y and Z			
Switching Frequency*	PWM mode	--	300	--	KHz
MTBF	MIL-HDBK-217F@25°C	1000	--	--	khours

Note:* This series of products using reduced frequency technology, the switching frequency is test value of full load, When the load is reduced to below 50%, the switching frequency decreases with decreasing load.

PHYSICAL CHARACTERISTICS

Parameter	Conditions	
Housing material		Aluminum alloy
Package Dimensions	Horizontal package	22.00 × 9.50 × 12.00 mm
	A2S chassis mounting	76.00*31.50*21.20 mm
	A4S DIN-rall mounting	76.00*31.50*25.80 mm
Weight	Horizontal package/A2S wiring package/A4S rall package	14g/36g/56g(Typ.)
Cooling mode		Free air convection

EMC CHARACTERISTICS

Parameter	Category	Content
EMI	Conducted disturbance	CISPR22/EN55022 CLASS A (Bare component)/ CLASS B (see Fig.3- for recommended circuit)
	Radiated emission	CISPR22/EN55022 CLASS A (Bare component)/ CLASS B (see Fig.3-2 for recommended circuit)

EMC CHARACTERISTICS

Parameter	Category	Content		
EMC	Electrostatic discharge	IEC/EN61000-4-2	Contact +4KV	perf. CriteriaB
	Radlation Immunity	IEC/EN61000-4-3	10V/m	perf. CriteriaA
	EFT	IEC/EN61000-4-4	±2KV (see Fig.3-① for recommended circuit)	perf. CriteriaB
	Surge Immunity	IEC/EN61000-4-5	±2KV (see Flg.3-1for recommended circuit)	perf. CriteriaB
	Conducted disturbance Immunity	IEC/EN61000-4-6	3 Vr.m.s	perf. CriteriaA
	Immunities of voltage dip, drop and short Interruption	IEC/EN61000-4-29	0-70%	perf. CriteriaB

CIRCUIT DESIGN AND APPLICATION

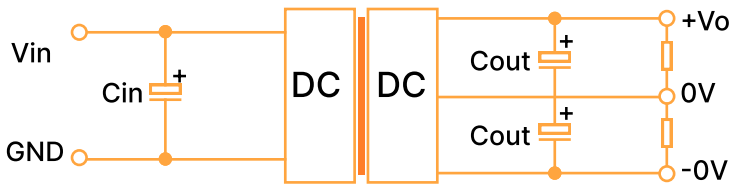

Figure 1: Application circuit

Table 1: Recommended Capacitive Load Values

VIn(VDC)	Cin(uF)	Cout(uF)
24	100	10
48	0~47	10

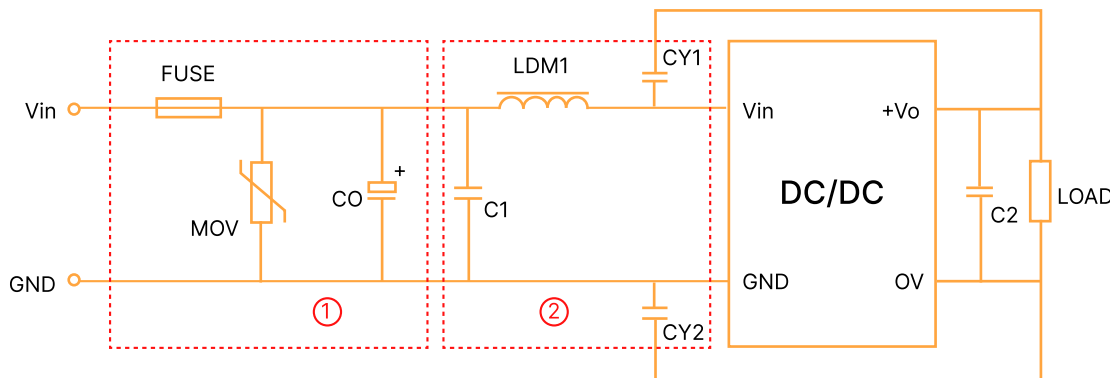

Figure 3

Notes: Part ① in the Fig. 3 is used for EMC test and part ② for EMI filtering; selected based on needs.

Fig. 3 Parameter description

Model	Vin:24V	Vin:48V
FUSE	Choose according to actual input current	
MOV	S14K35	\$14K60
C0	330μF/50V	330μF/100V
C1	1μF/50V	1μF/100V
C2	Refer to the Cout In Flg.2	
LDM1	4.7UH	
CY1.CY2	1nF/2KV	

1. Typical application: If further reduction of input and output ripple is required, a capacitor Filter network can be connected at the input and output ends. The application circuit is shown in Figure 1. However, suitable Filter capacitors should be selected. If the capacitance is too large, it may cause overcurrent or poor startup of the power supply. For each output, while ensuring safe and reliable operation, the recommended capacitance load values are shown in Table 1.
2. EMC requirements: For situations with high EMC requirements, a typical EMC recommended circuit is shown in Figure 2.
3. Input requirements: Ensure that the Fluctuation range of the input voltage does not exceed the upper and lower limits of the input voltage Specified in this data sheet, and the input power must be greater than the output power Specified in this data sheet. For situations with a 24V input voltage, it is recommended to connect a TVS tube between the positive and negative input pins for protection (recommended parameters for TVS tubes: 30V, bidirectional, SOD-123 packaging).
4. Output load requirements: Try to avoid using it without load as much as possible; When the actual power of the load is less than 10% of the rated output power in this data sheet, or when it needs to be used in no-load situations, it is recommended to connect a load resistor externally at the output end. The load resistor can be calculated according to 5-10% of the rated power in this data sheet. The calculation formula for the load resistor value is $RL = V_{out}^2 / (P_{out} * 10\%)$.
5. Overload protection: Under normal working conditions, the output circuit of this product has no protection function for overload situations. The simplest method is to connect a self recovery fuse in series at the input end, or add a circuit breaker outside the circuit; Or during design and selection, the actual power of the circuit should be around 60-80% of the rated power in this data sheet.

PRODUCT CHARACTERISTIC CURVE

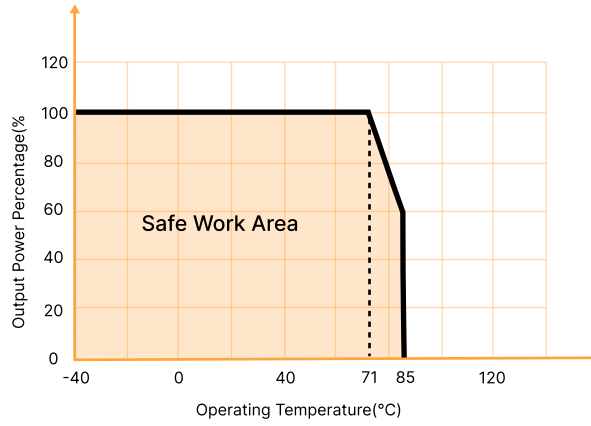

Figure 4: Temperature Derating Curve

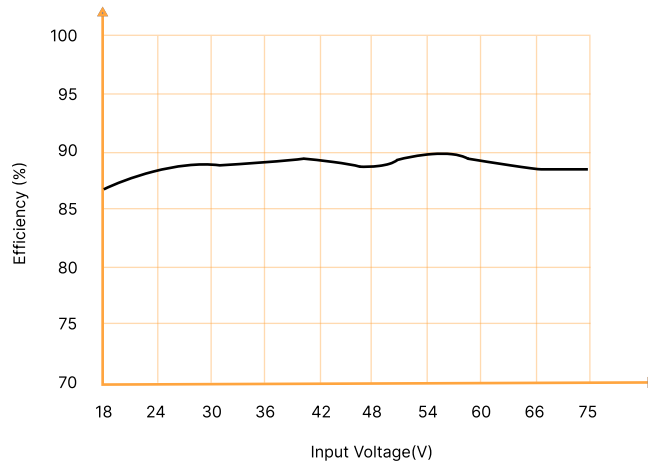

Fig: 1 Efficiency Vs Input Voltage (Full Load)

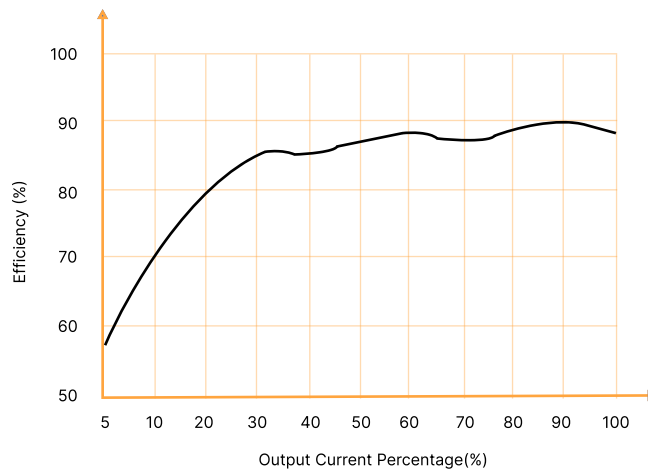

Fig: 1 Efficiency Vs Output Load (Vin=Vin-nominal)

OVERALL DIMENSIONS AND PIN FUNCTIONS

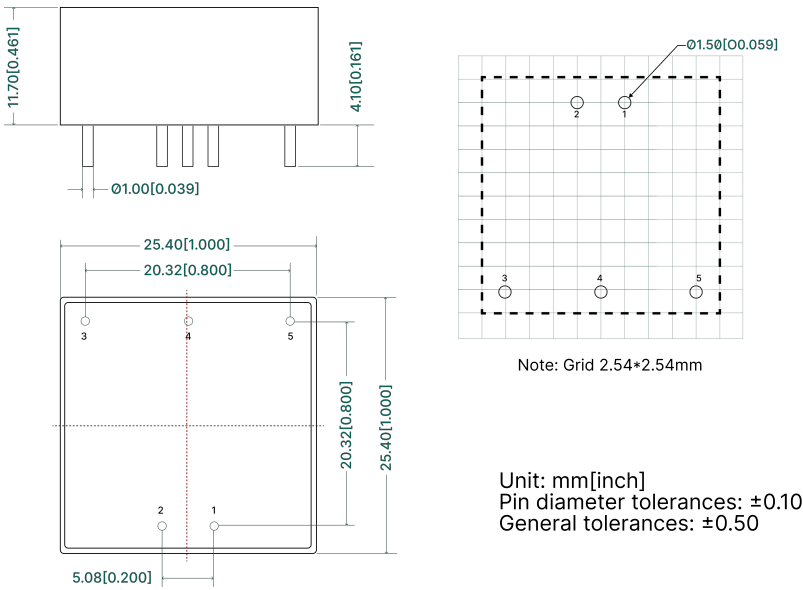

Table 3: Pin Function Table

Pin	Function
1	GND
2	Vin
3	+V0
4	0V
5	-V0

*NC cannot be connected to any external circuits

Figure 7: Overall dimensions

PACKAGING METHOD

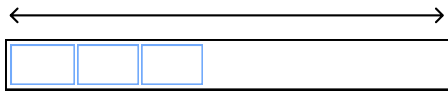

16 Pieces/Tube

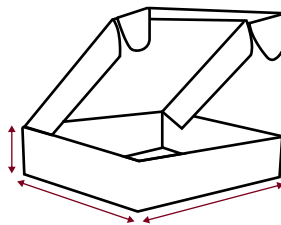

432 Pieces/Inner box

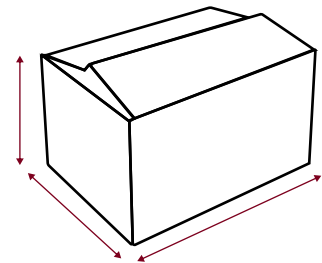

2160 Pieces/Outer box

NOTES & INSTRUCTIONS

- 1.The input voltage shall not exceed the specified range value, otherwise permanent and unrecoverable damage maybe caused;
2. Unless otherwise specified,the parameters in this manual are measured at 25 °C,40%~75% humidity, input nominal voltage and output pure resistance mode under full load;
- 3.All index test methods are based on the company's enterprise standards.
- 4.The copyright and the final interpretation right of the product belong to HENXV.