

DCWF1DxxQB-75W



FEATURES

- Low no-load power consumption
- Input under-voltage protection, output short-circuit, over-current, over-voltage, over-temperature protection
- Industry standard 1/4 brick
- High efficiency up to 90%
- Ultra-wide input voltage range: 43-160VDC
- Operating ambient temperature range: -40°C to +105°C
- Reinforced insulation, input - output isolation test voltage: 3k VAC, input - case isolation test voltage: 2.1k VAC

Applications

- Railway systems

MODEL NUMBERING

DCWF1DxxQB-75W

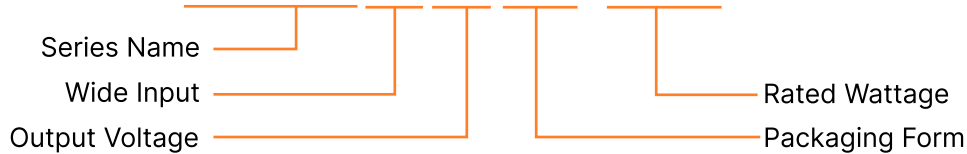

SELECTION GUIDE

Product Model	Input Voltage Range (Nominal/Max)	Output Voltage	Output Current (mA) (Max./Min.)	Efficiency % (Min./Typ.)	Maximum Capacitive load (μ F)
DCWF1D03QB-75W	43-160 (110/170)	3.3	17045/0	84/86	30000
				82/84	
DCWF1D05QB-75W		5	15000/0	86/88	15000
				84/86	
DCWF1D12QB-75W		12	6250/0	87/89	4500
				85/87	
DCWF1D15QB-75W		15	5000/0	87/89	3600
			85/87		
DCWF1D24QB-75W	24	3125/0	88/90	2250	
			86/88		
DCWF1D48QB-75W	48	1563/0	86/88	360	
			84/86		

Note: *Use suffix "ST" for chassis mounting, suffix "H" for heatsink and suffix "DR" for Din-Rail mounting

INPUT CHARACTERISTICS

Parameter	Operating Conditions	Min.	Typ.	Max.	Units	
Input Current (full load / no-load)	Nominal input voltage	3.3VDC output	--	595/10	609/20	mA
		24VDC output	--	758/10	775/20	mA
		12VDC, 15VDC output	--	767/10	784/20	mA
		05VDC, 48VDC output	--	775/10	793/20	mA
Reflected Ripple Current	Nominal input voltage	--	100	--	mA	
Surge Voltage (1sec. max.)		-0.7	--	180	VDC	
Start-up Voltage		--	--	43	VDC	
Under-voltage Protection		--	40	--	VDC	
Input Filter		Pi filter				
Ctrl*	Module on	Ctrl pin open or pulled high (3.5-12VDC)				
	Module off	Ctrl pin -Vin or pulled low (0-1.2VDC)				
	Input current when off	--	2	10	mA	

OUTPUT CHARACTERISTICS

Parameter	Operating Conditions	Min.	Typ.	Max.	Units	
Voltage Accuracy	Nominal input voltage, 0%-100% load	--	±1	±3	%	
Linear Regulation	Input voltage variation from low to high at full load	3.3VDC, 5VDC output	--	--	±0.5	%
		Others	--	±0.1	±0.3	%
Load Regulation	Nominal input voltage, 10%-100% load	3.3VDC, 5VDC output	--	±0.5	±1.0	%
		Others	--	±0.3	±0.5	%
Transient Recovery Time		--	200	500	µs	
Transient Response Deviation	25% load step change	3.3VDC, 5VDC output	--	±6	±9	%
		Others	--	±3	±5	%
Temperature Coefficient	Full load	--	--	±0.03	%/°C	
Trim		90	--	110	%	

Parameter	Operating Conditions		Min.	Typ.	Max.	Units
Ripple & Noise *	Input voltage variation from low to high at full load	48VDC output	--	200	300	mVp-p
		Others	--	100	200	mVp-p
Output Voltage Remote Compensation(Sense)			--	105	105	%
Over-Voltage Protection	Input Voltage Range	3.3VDC,5VDC output	110	--	160	%Vo
		Others	110	--	140	%Vo
Over-Temperature Protection	Surface Max. Temperature		--	105	115	°C
Over-Current Protection	Input Voltage Range		110	140	190	%Io
Short-Circuit Protection			Hiccup, continuous, self-recovery			

GENERAL CHARACTERISTICS

Parameter	Operating Conditions		Min.	Typ.	Max.	Units
Isolation	Input-output	Electric Strength test for 1 minute with a leakage current of 5mA max.	3000	--	--	VAC
	Input-case		2100	--	--	VAC
	Output-case	Electric Strength test for 1 minute with a leakage current of 1mA max.	1500	--	--	VDC
Insulation Resistance	Input-output resistance at 500VDC		1000	--	--	MΩ
Isolation Capacitance	Input-output capacitance at 100KHz/0.1V		--	2200	--	pF
Switching Frequency	PFM mode		--	170	--	KHz
MTBF	MIL-HDBK-217F@25°C		500	--	--	K hours
Operating Temperature Range	See temperature derating curves		-40	--	+105	°C
Storage Humidity	Non-condensing		5	--	95	%RH
Storage Temperature			-55	--	+125	°C
Pin Soldering Resistance Temperature	Soldering spot is 1.5mm away from case for 10 seconds		--	--	+300	°C
Cooling Test			EN60068-2-1			
Dry Heat			EN60068-2-2			
Damp Heat			EN60068-2-30			
Shock and Vibration Test			IEC/EN61373 - Category 1, Grade B			

EMC CHARACTERISTICS

	Parameter	Category	Content	
EMI	CE	CISPR32/EN55032 150KHz-30MHz	Class B (see Fig. 3 for recommended circuit)	
	RE*	CISPR32/EN55032 30MHz-1GHz	Class B (see Fig. 3 for recommended circuit)	
EMC	ESD	IEC/EN61000-4-2 GB/T17626.2	Contact ±6KV, Air ±8KV	perf. Criteria A
	RS	IEC/EN61000-4-3 GB/T17626.3	20V/m	perf. Criteria A
	EFT	IEC/EN61000-4-4 GB/T17626.4	±2KV (5KHz, 100KHz) (see Fig. 3 for recommended circuit)	perf. Criteria A
	Surge	IEC/EN61000-4-5	GB/T17626.5 line to line ±2KV (1.2µs/50µs 2Ω) (see Fig. 3 fo recommended circuit)	perf. Criteria A
	CS	IEC/EN61000-4-6 GB/T17626.6	10Vr.m.s	perf. Criteria A

EMC CHARACTERISTICS (EN50155)

	Parameter	Category	Content	
EMI	CE	EN50121-3-2	150kHz-500kHz 99dBuV (see Fig.2for recommended circuit)	
		EN55016-2-1	500kHz-30MHz 93dBuV (see Fig.2 for recommended circuit)	
EMI	RE	EN50121-3-2	30MHz-230MHz 40dBuV/m at 10m(see Fig.2 for recommended circuit)	
		EN55016-2-1	230MHz-1GHz 47dBuV/m at 10m (see Fig. 2 for recommended circuit)	
EMC	ESD	EN50121-3-2	Contact ±6KV/Air ±8KV	perf. CriteriaA
	RS	EN50121-3-2	20V/m	perf. CriteriaA
	EFT	EN50121-3-2	±2kV 5/50ns 5kHz (see Fig. 2 for recommended circuit)	perf. CriteriaA
	Surge	EN50121-3-2	line to line ±1KV (42Ω, 0.5µF) (see Fig. 2 for recommended circuit)	perf. CriteriaA
	CS	EN50121-3-2	0.15MHz-80MHz 10V r.m.s	perf. CriteriaA

PHYSICAL CHARACTERISTICS

Parameter	Conditions	
Case Material	Aluminum alloy case; Black plastic bottom, flame-retardant and heat-resistant (UL94 V-0)	
Dimensions	DCWF1DxxQB-75W	60.80 × 39.20 × 12.70 mm
	DCWF1DxxQB-75WH	61.50 × 39.20 × 27.70 mm
	DCWF1DxxQB-75WST	135.00 × 70.00 × 22.60 mm
	DCWF1DxxQB-75WDR	137.00 × 70.00 × 28.10 mm

PHYSICAL CHARACTERISTICS

Parameter	Conditions	
Dimensions	DCWF1DxxQB-75WST	135.00 × 70.00 × 36.20 mm
	DCWF1DxxQB-75WDR	137.00 × 70.00 × 41.70 mm
Weight	DCWF1DxxQB-75W	88.0g (Typ.)
	DCWF1DxxQB-75WH	119.0g (Typ.)
	DCWF1DxxQB-75WST	164.0g (Typ.)
	DCWF1DxxQB-75WDR	237.0g (Typ.)
	DCWF1DxxQB-75WST	200.0g (Typ.)
	DCWF1DxxQB-75WDR	268.0g (Typ.)
	DCWF1DxxQB-75WDR	268.0g (Typ.)
Cooling Method	Free air convection or forced convection	

PRODUCT CHARACTERISTIC CURVE

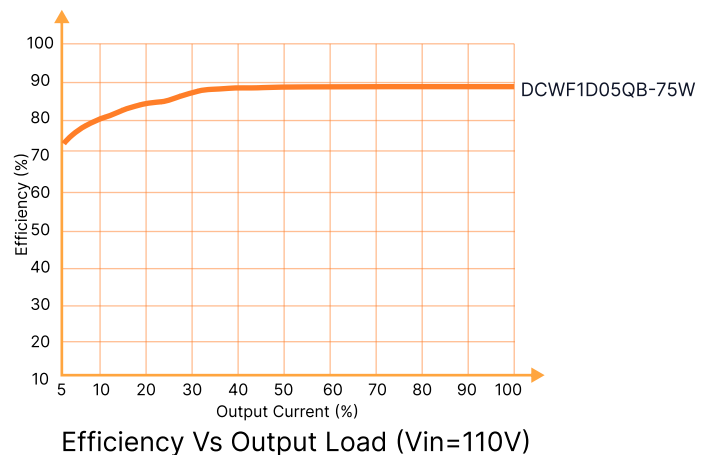
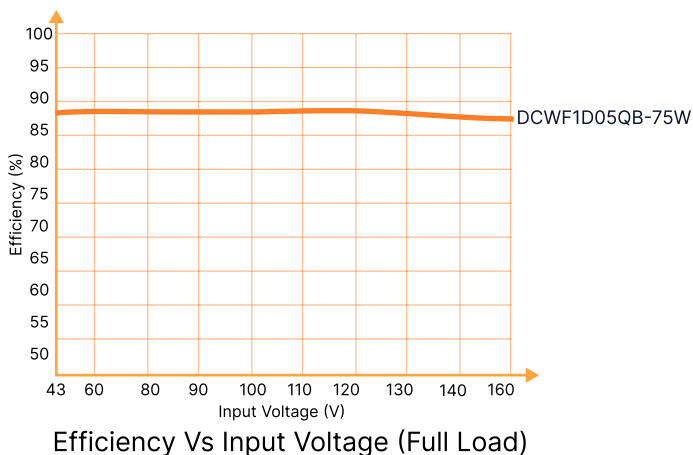
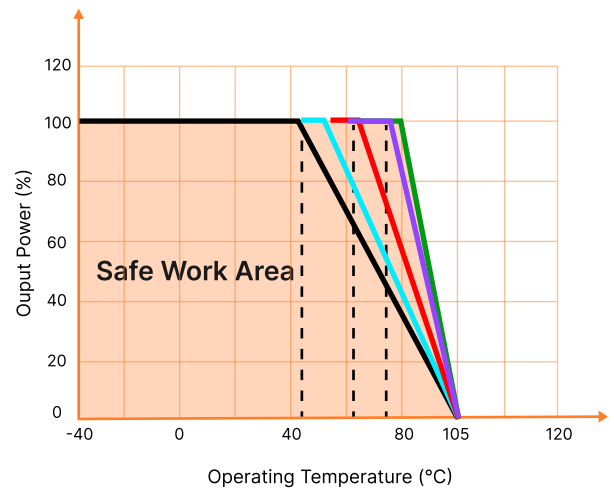
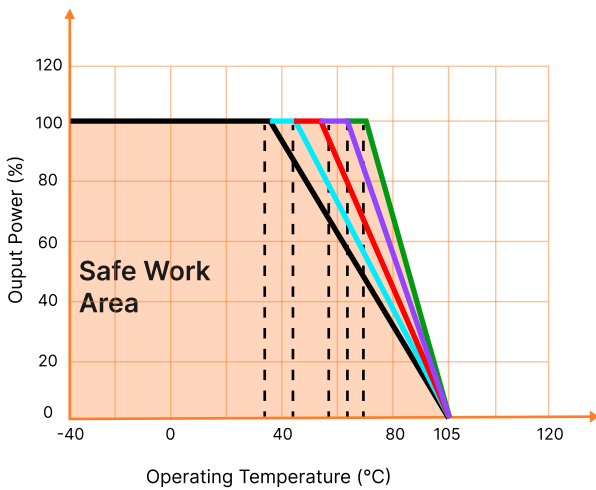

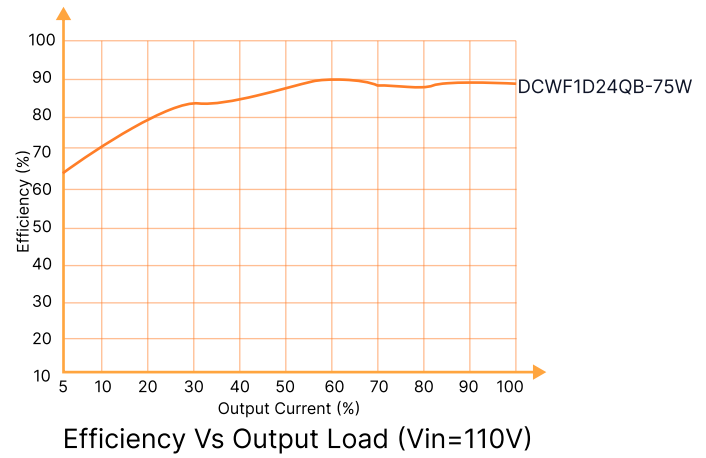
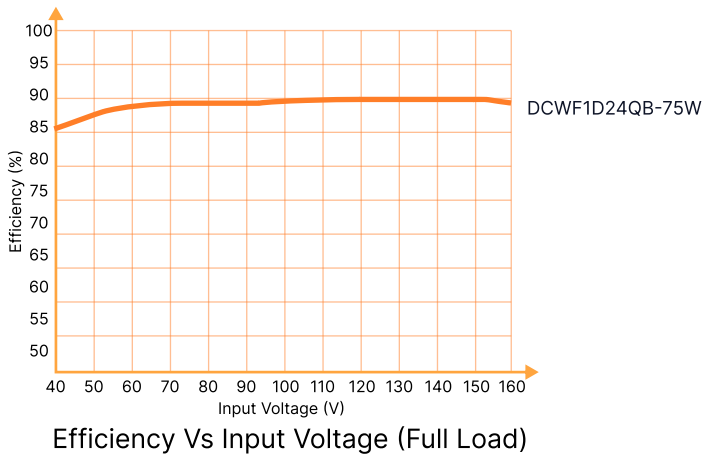

CIRCUIT DESIGN AND APPLICATION

1. Remote Sense Application

1. Remote Sense Connection if not used

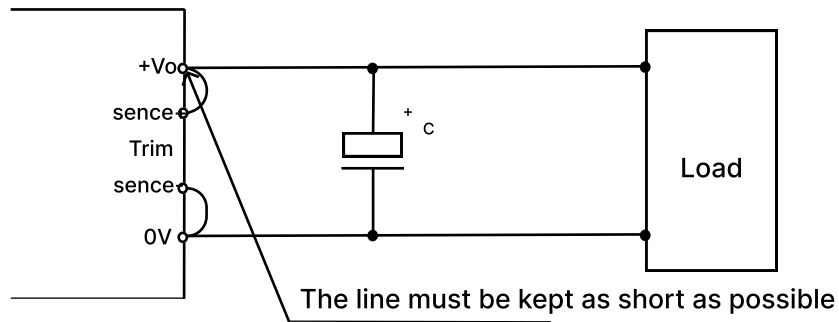

Notes :

1. If the sense function is not used for remote regulation the user must connect the +Sense to + Vo and -Sense to 0V at the DC-DC converter pins and will compensate for voltage drop across pins only.
2. The connections between Sense lines and their respective power lines must be kept as short as possible, otherwise they may be picking up noise, interference and/or causing unstable operation of the power module.

2. Remote Sense Connection used for Compensation

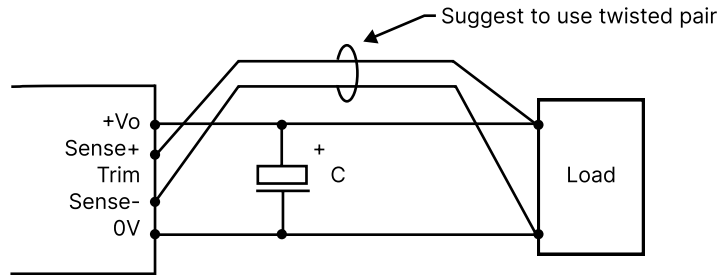

Notes:

1. Using remote sense with long wires may cause unstable output, please contact technical support if long wires must be used.
2. PCB-tracks or cables/wires for Remote Sense must be kept as short as possible. Twisted pair or shielded wires are suggested for remote compensation and must be kept as short as possible.
3. We recommend using adequate cross section for PCB-track layout and/or cables to connect the power supply module to the load in order to keep the voltage drop below 0.3V and to make sure the power supply's output voltage remains within the specified range.
4. Note that large wire impedance may cause oscillation of the output voltage and/or increased ripple. Consult technical support or factory for further advice of sense operation.

1. Ripple & noise

All the DC-DC converters of this series are tested before delivery using the recommended circuit shown in Fig. 1

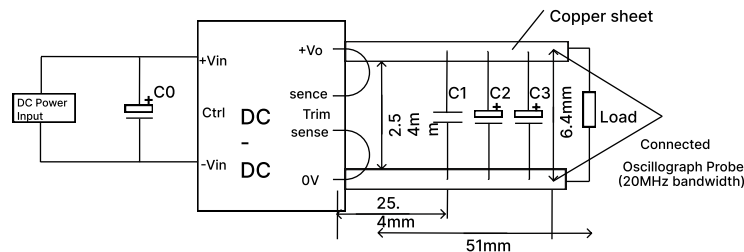

Capacitors Output Voltage Value	C0(μF)	C1(μF)	C2(μF)	C3(μF)
3.3VDC	100	1	10	1000
05VDC				680
12VDC				220
15VDC				220
24VDC				220
48VDC				220

2. Typical application

We recommended using RHENXV's EMC circuit, otherwise please ensure that at least a 100μF electrolytic capacitors is connected at the input in order to ensure adequate voltage surge suppression and protection.

Input and/or output ripple can be further reduced by appropriately increasing the input & output capacitor values C_{in} and C_{out} and/or by selecting capacitors with a low ESR (equivalent series resistance). Also make sure that the capacitance is not exceeding the specified max. capacitive load value of the product.

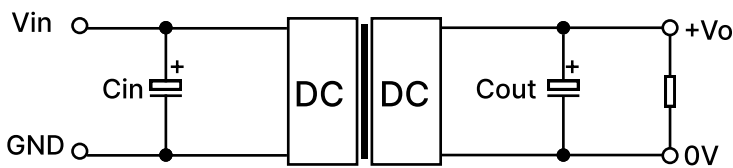

Figure 2: Application circuit

Output voltage	C_{in} (μF)	C_{out} (μF)
3.3VDC	100	1000
5VDC		680
12VDC		220
15VDC		220
24VDC		220
48VDC		220

3. EMC compliance recommended circuit

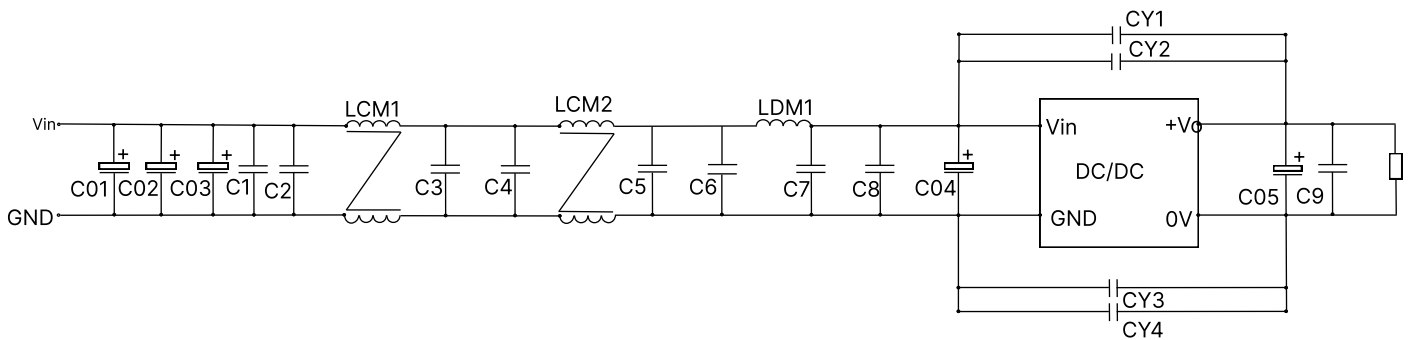

Fig.2

Components	Value
C01, C02, C03, C04	220uF/200V (electrolytic capacitor)
C05	220uF/63V (electrolytic capacitor)
LDM1	1.5uH (Shielded inductor)
C1, C2, C3, C4, C5, C6, C7, C8, C9	2.2uF/250V
CY1, CY2, CY3, CY4	2200 pF /400VAC (Y safety capacitor)
LCM1	4700*2 (μH) /3A
LCM2	1000*2 (μH) /3A

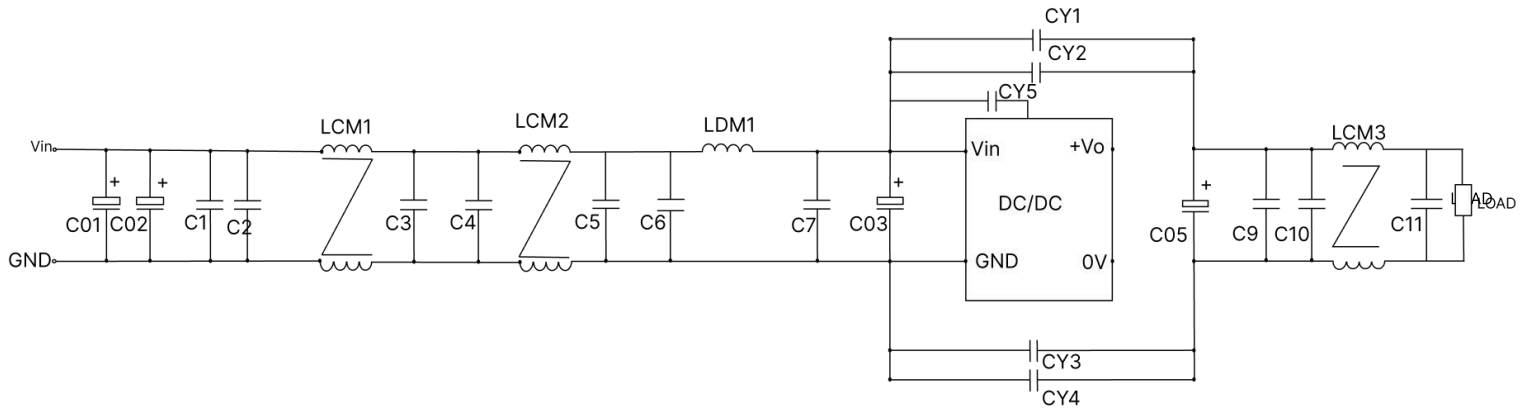
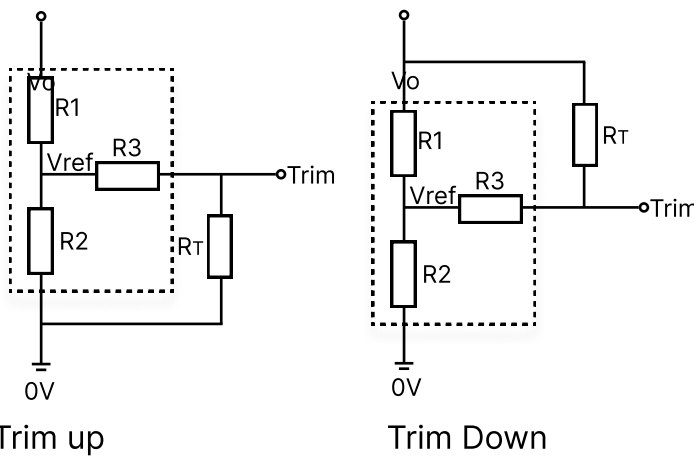

Fig.3

Components	Value
C01, C02, C03, C04	220uF/200V (electrolytic capacitor)
C05	220uF/63V (electrolytic capacitor)
LDM1	1.5uH (Shielded inductor)
C1, C2, C3, C4, C5, C6, C7, C8, C9, C10, C11	2.2uF/250V
CY1, CY2, CY3, CY4	2200 pF /400VAC (Y safety capacitor)
LCM1	4700*2 (μH) /3A
LCM2	1000*2 (μH) /3A
LCM3	36*2 (μH) /7A
	36*2 (μH) /13A
	36*2 (μH) /25A

3. Trim Function for Output Voltage Adjustment (open if unused)



The Calculation formula for trip resistance

$$\text{Trim up: } R_T \frac{aR_2}{R_2-a} - R_3 \quad a = \frac{V_{ref}}{V_o' - V_{ref}} R_1$$

$$\text{Trim down: } R_T \frac{aR_1}{R_1-a} - R_3 \quad a = \frac{V_o' - V_{ref}}{V_{ref}} R_2$$

R_T is Trim resistance
 a is a self-defined parameter, with no real meaning.

TRIM resistor connection (dashed line shows internal resistor network)

Vout(V)	3.3(VDC)	05(VDC)	12(VDC)	15(VDC)	24(VDC)	48(VDC)
R1(KΩ)	4.74	8.74	11	14.49	24.87	58.7
R2(KΩ)	2.87	2.87	2.87	2.87	2.87	3.21
R3(KΩ)	9.66	11	11	16	21	11
Vref(V)	1.25	1.25	2.5	2.5	2.5	2.5

Note : .
 For R1, R2, R3 and Vref values refer to table 1.
 RT = Trim Resistor value; .a = self-defined parameter
 Vo'= desired output voltage

DIMENSIONS AND INSTALLATION

DCWF1D-QB-75W (without heatsink)

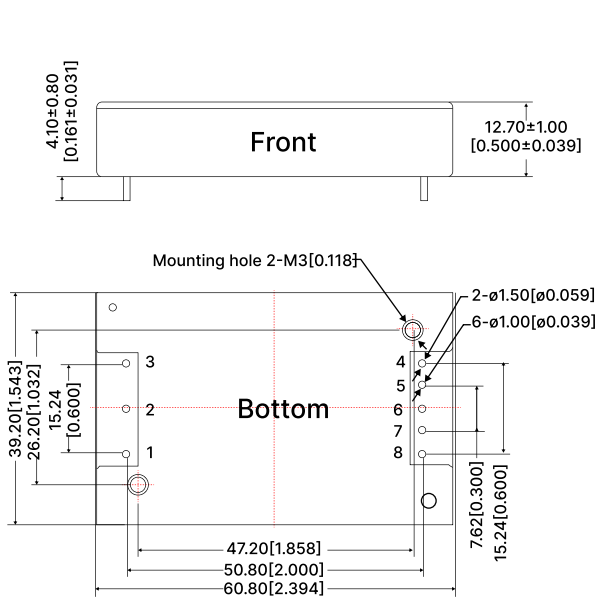

Note:
 Unit: mm[inch]
 PIN 1, 2, 3, 4, 6, 7's Diameter: 1.00[0.039]
 PIN 4, 8's Diameter: 1.50[0.059]
 PIN Diameter Tolerance: ±0.10[±0.004]
 General Tolerances: ±0.50[±0.020]
 Mounting Hole Screwing Torque: Max 0.4 N.m

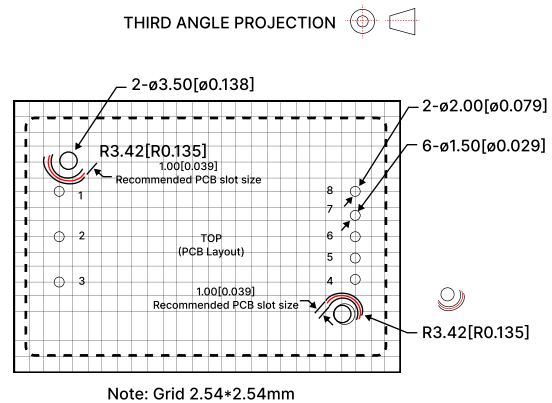

Pin	Function	Pin	Function
1	+Vin	5	Sense-
2	Ctrl	6	Trim
3	-Vin	7	Sense+
4	0V	8	+V0

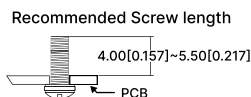

DCWF1D-QB-75WH (with heatsink)

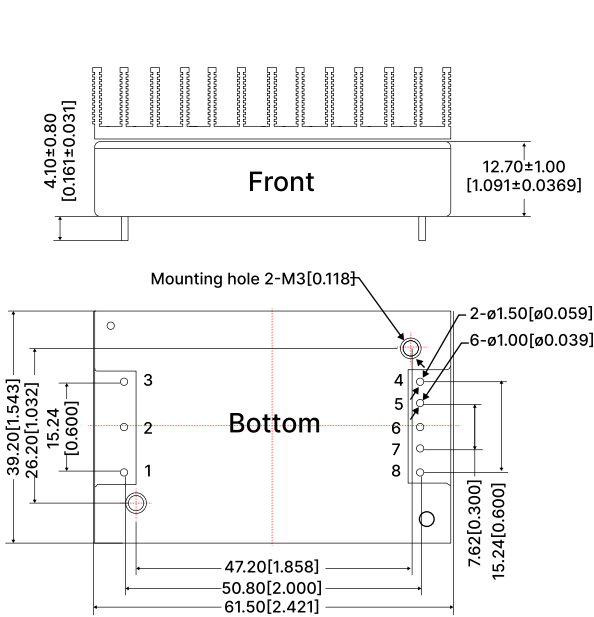

Note:
Unit: mm[inch]
PIN 1, 2, 3, 4, 6,7's Diameter: 1.00[0.039]
PIN 4, 8's Diameter: 1.50[0.059]
PIN Diameter Tolerance: ±0.10[±0.004]
General Tolerances: ±0.50[±0.020]
Mounting Hole Screwing Torque: Max 0.4 N.m

THIRD ANGLE PROJECTION

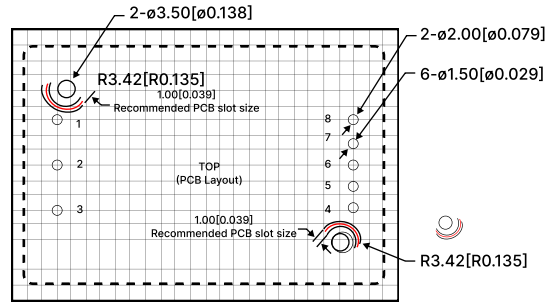

Note: Grid 2.54*2.54mm

Pin	Function	Pin	Function
1	+Vin	5	Sense-
2	Ctrl	6	Trim
3	-Vin	7	Sense+
4	0V	8	+V0

Recommended Screw length

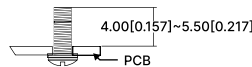

DCWF1D-QB-75WST (without heatsink)

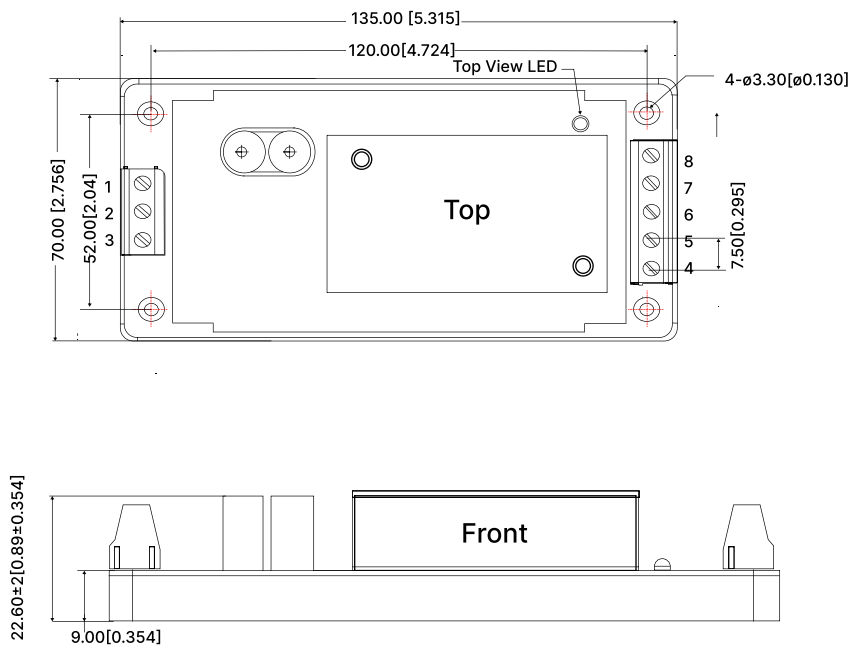

Pin	Function
1	+Vin
2	Ctrl
3	-Vin
4	0V
5	Sense-
6	Trim
7	Sense+
8	+Vo

Note:
Unit: mm[inch]
Wire Range: 16-12 AWG
Tightening Torque: Max:0.4 N-m
General Tolerances: ±1.00[±0.040]

DCWF1D-QB-75WDR (without heatsink)

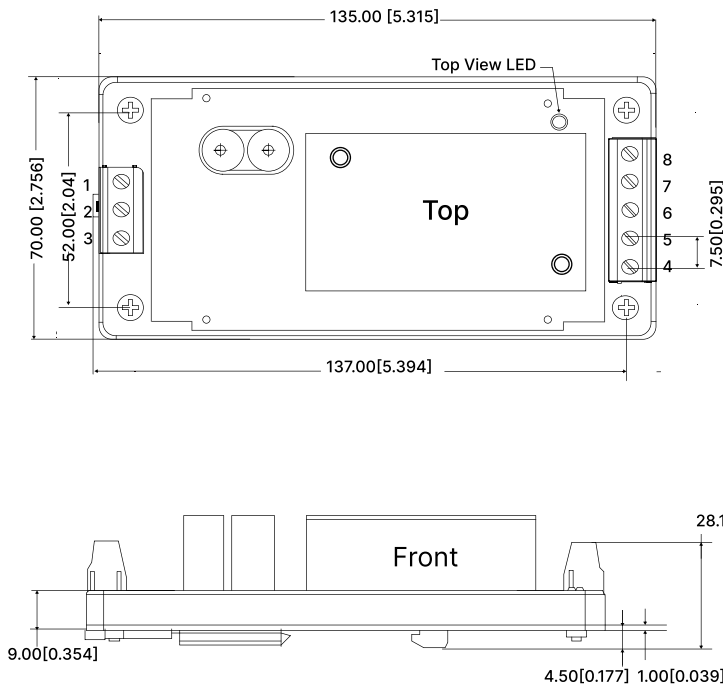

Pin	Function
1	+Vin
2	Ctrl
3	-Vin
4	0V
5	Sense-
6	Trim
7	Sense+
8	+Vo

Note:
Unit: mm[inch]
Wire Range: 16-12 AWG
Tightening Torque: Max:0.4 N-m
Installed on DIN RAIL TS35
General Tolerances: ±1.00 [±0.040]

DCWF1D-QB-75WHST (with heatsink)

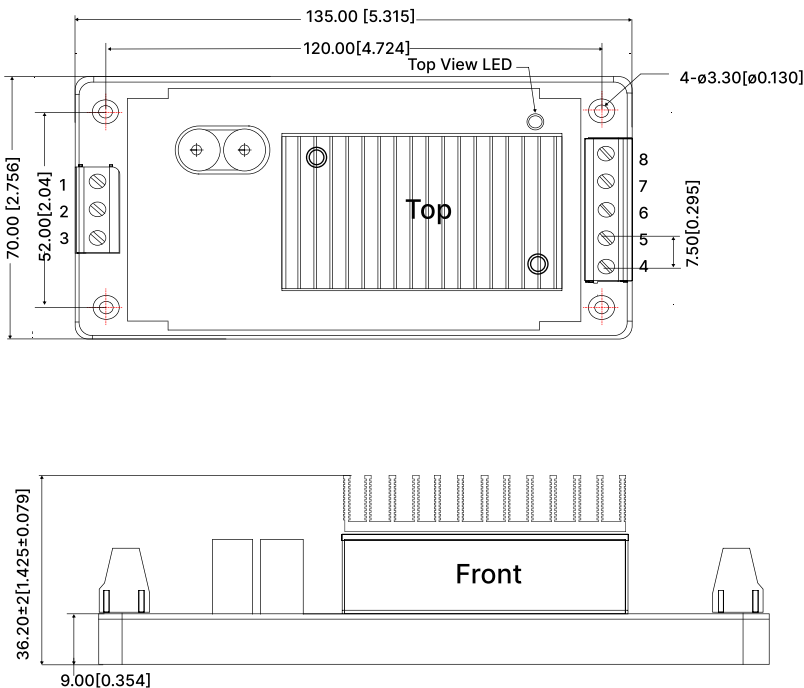

Pin	Function
1	+Vin
2	Ctrl
3	-Vin
4	0V
5	Sense-
6	Trim
7	Sense+
8	+Vo

Note:
Unit: mm[inch]
Wire Range: 16-12 AWG
Tightening Torque: Max:0.4 N-m
General Tolerances: ±1.00 [±0.040]

DCWF1D-QB-75WHDR (with heatsink)

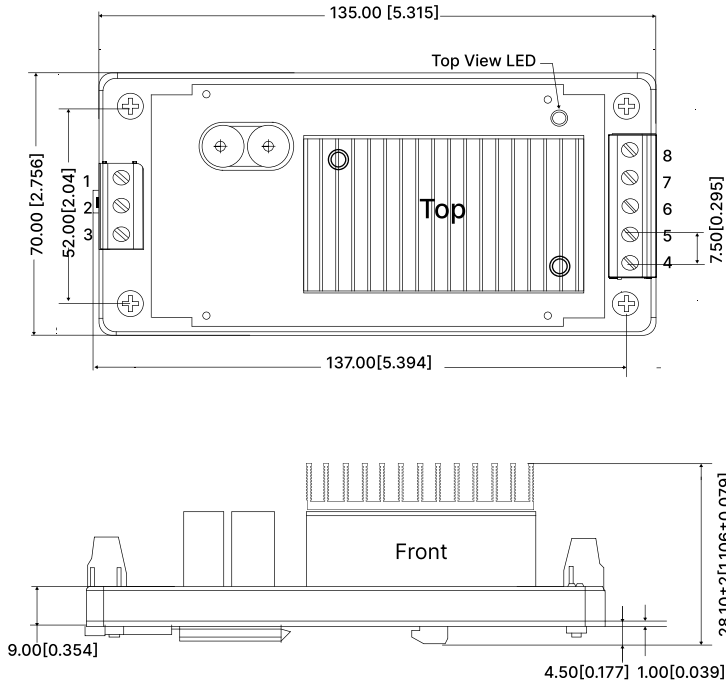

Pin	Function
1	+Vin
2	Ctrl
3	-Vin
4	0V
5	Sense-
6	Trim
7	Sense+
8	+Vo

Note:
 Unit: mm[inch]
 Wire Range: 16-12 AWG
 Tightening Torque: Max:0.4 N-m
 Installed on DIN RAIL TS35
 General Tolerances: ±1.00[±0.040]