

DCWF1D_HB-250W



FEATURES

- Wide input voltage range: 40 -160VDC
- Input under-voltage protection, output over-voltage, over-current, short-circuit protection, over-temperature protection
- Operating ambient temperature range -40°C to +105°C
- High efficiency up to 90%
- Reinforced insulation, I/O isolation test voltage 3k VAC

APPLICATIONS

- Centralized Lighting
- Air Conditioning Related In On-Board Equipment

MODEL NUMBERING

DCWF1DxxHB-250W



SELECTION GUIDE

Product Model	Ctrl Logic ②	Input Voltage (VDC)			Output		Full Load Efficiency (%) Min./Typ.	Max. Capacitive Load (µF)	
		Nominal	Range	Max.③	Voltage (VDC)	Current (mA) Max./Min.			
DCWF1D05HB-250W	P	110	40-66	170	5	40000/0	87/88	22000	
			66-160						
DCWF1D12HB-250W	P		40-66		12	16670/0	88/90	10000	
			66-160			20840/0			
DCWF1D15HB-250W	P		40-66		15	13330/0	88/90	6800	
			66-160			16670/0			
DCWF1D24HB-250W	P		40-66		24	8330/0	88/90	4000	
			66-160			10420/0			
DCWF1D40HB-250W	P		40-66		40	5000/0	87/89	680	
			66-160			6250/0			
DCWF1D48HB-250W	P		40-66		48	4160/0	88/90	680	
			66-160			5200/0			
DCWF1D54HB-250W	P		40-66		54	3700/0	88/90	680	
			66-160			4630/0			

Note: 1. Use suffix "ST" for screw terminal, suffix "DR" for DIN-Rail
 2. "P" means positive logic, "N" means negative logic;

INPUT CHARACTERISTICS

Parameter	Operating Conditions		Min.	Typ.	Max.	Units
Input current (Rated Load/no-load)	Nominal input voltage	5V output	--	2582/50	2612/70	mA
		Others	--	2526/50	2582/70	mA
Reflected Ripple Current	Nominal input voltage		--	100	--	mA
Input Impulse Voltage	(1 Sec. max)		-0.7	--	185	VDC
Start-up Voltage			--	--	40	VDC
Under Voltage Protection			32	36	--	VDC
Start Time	Nominal input voltage & constant resistance load		--	40	100	ms
Input Filter			Pi filter			
Ctrl *	Module on		Ctrl pin open or pulled high (3.5-12VDC)			
	Module off		Ctrl pin pulled low to GND(0-1.2VDC)			
	Input current when off		--	5	10	mA

Note: *The Ctrl pin voltage is referenced to input GND

Note: Hot plug-unavailable

OUTPUT CHARACTERISTICS

Parameter	Operating Conditions		Min.	Typ.	Max.	Units
Output Voltage Accuracy	0%-100% load		--	±1	±3	%
Linear Regulation Rate	Input voltage variation from low to high at full load		--	±0.2	±0.5	%
Load Regulation Rate	Nominal input voltage, 0%-100% load	5V output	--	±0.8	±1.0	%
		Others	--	±0.4	±0.5	%
Dynamic Response Recovery Time	25% load step change@25°C		--	200	500	µs
Dynamic Response Step Deviation			--	±3	±5	%
Temperature Drift Coefficient	Full load		--	--	±0.03	%/°C
Ripple & Noise	20MHz bandwidth, nominal input voltage, 100% load		--	120	200	mVp-p

Parameter	Operating Conditions	Min.	Typ.	Max.	Units
Trim		90	--	110	%Vo
Sense		--	--	105	%Vo
Over-Temperature Protection	Max. Case Temperature	--	105	115	%Vo
Output Overvoltage Protection	Input Voltage Range	110	130	160	%Vo
Output Overcurrent Protection	43VDC -66VDC	110	160	220	%Io
	66VDC -160VDC	110	140	150	%Io
Short-Circuit Protection	Hiccup, continuous, self-recovery				

Note: ① By measuring method is used for Ripple and Noise test, please refer to Fig. 2. for recommended circuit.

GENERAL CHARACTERISTICS

Parameter	Operating Conditions	Min.	Typ.	Max.	Units	
Isolation Voltage	Input/output-Case Electric Strength Test for 1 minute with a leakage current of 5mA max.	Input - Output	3000	--	--	VAC
		Input - Case	1500	--	--	VAC
		Output - Case	1500	--	--	VAC
Insulation Resistance	Input-output resistance at 500VDC	100	--	--	MΩ	
Isolation Capacitance	Input-output capacitance at 100KHz/0.1V	--	1000	--	pF	
Working Temperature	See Fig. 1	-40	--	+105	°C	
Storage Temperature		-55	--	+125	°C	
Storage Humidity	Non-condensing	5	--	95	%RH	
Soldering Temperature Resistance Of Pins	Soldering spot is 1.5mm away from case for 10 seconds	--	--	300	°C	
	Wave soldering, 10 seconds	255	260	265	°C	
Switching Frequency *	PFM mode	--	260	--	KHz	
MTBF	MIL-HDBK-217F@25°C	1000	--	--	Khours	

Parameter	Operating Conditions	Min.	Typ.	Max.	Units
Shock & Vibration		IEC/EN61373 - Category 1, Grade B			
Dry Heat Requirement		EN60068-2-2			
Damp Heat Requirement		EN60068-2-30			
Cooling Requirement		EN60068-2-1			

PHYSICAL CHARACTERISTICS

Parameter	Conditions		
Case Material	Black plastic bottom, flame-retardant and heat-resistant (UL94V-0)		
Dimensions	Without heat sink	Horizontal package	61.00 × 57.90 × 13.80 mm
		Screw Terminal (ST)	135.00 × 70.00 × 22.40 mm
	With heat sink	Horizontal package	62.00 × 58.00 × 31.80 mm
		Screw Terminal (ST)	135.00 × 70.00 × 40.40 mm
Weight	Without heat sink	Horizontal package	135g (Typ.)
		Screw Terminal (ST)(05/12/15HB)	235g (Typ.)
		Screw Terminal (ST)(24/40/48/54HB)	214g (Typ.)
	With heat sink	Horizontal package	185g (Typ.)
		Screw Terminal (ST)(05/12/15HB)	285g (Typ.)
		Screw Terminal (ST)(24/40/48/54HB)	264g (Typ.)
Cooling Method	Free air convection (20LFM) or forced air convection		

NOTE

1. If the product works under the minimum required load, it cannot guarantee that the performance of the product complies with all the performance indicators in this manual;
2. The maximum capacitive load is tested under the input voltage range and full load condition;
3. Unless otherwise stated, all indexes in this manual are measured at Ta=25°C, humidity <75%RH, nominal input voltage and rated output load;
4. All index testing methods in this manual are based on the enterprise standards of the company;
5. Our company can provide product customization, specific needs can directly contact our technical staff;

EMC CHARACTERISTICS

Parameter	Category	Content		
EMI	CE	CISPR32/EN55032	CLASS A (see Fig.3 for recommended circuit)	
	RE	CISPR32/EN55032	CLASS A (see Fig.3 for recommended circuit)	
EMC	ESD	IEC/EN61000-4-2	Contact $\pm 6KV$ Air $\pm 8KV$	perf. Criteria A
	RS	IEC/EN61000-4-3	20V/m	perf. Criteria A
	EFT	IEC/EN61000-4-4	$\pm 2KV$ (see Fig.3 for recommended circuit)	perf. Criteria A
	Surge	IEC/EN61000-4-5	differential mode $\pm 1KV$, 1.2/50us, source impedance 2Ω (see Fig.3 for recommended circuit)	perf. Criteria A
	CS	IEC/EN61000-4-6	10 Vr.m.s	perf. Criteria A

Parameter	Category	Content		
EMI	CE	EN50121-3-2	150kHz-500kHz 99dBuV (see Fig.3 for recommended circuit)	
		EN55016-2-1	500kHz-30MHz 93dBuV	
	RE	EN50121-3-2	30MHz-230MHz 40dBuV/m at 10m (see Fig.3 for recommended circuit)	
		EN55016-2-1	230MHz-1GHz 47dBuV/m at 10m	
EMC	ESD	EN50121-3-2	Contact $\pm 6KV$ Air $\pm 8KV$	perf. Criteria A
	RS	EN50121-3-2	20V/m	perf. Criteria A
	EFT	EN50121-3-2	$\pm 2kV$ 5/50ns 5kHz (see Fig.3 for recommended circuit)	perf. Criteria A
	Surge	EN50121-3-2	line to line $\pm 1KV$ (42Ω , $0.5\mu F$) (see Fig.3 for recommended circuit)	perf. Criteria A
	CS	EN50121-3-2	0.15MHz-80MHz 10Vr.m.s	perf. Criteria A

PRODUCT CHARACTERISTIC CURVE

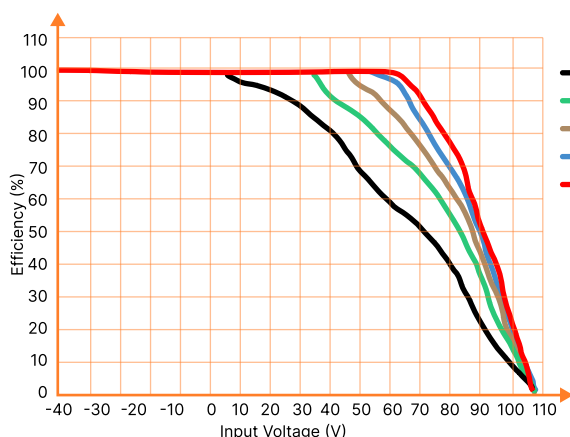

DCWF1D05HB-250W
Temperature Derating Curve

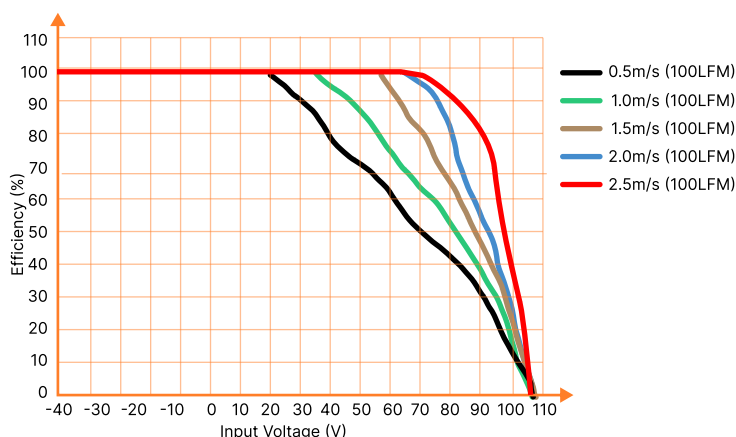

DCWF1D12HB-250W
Temperature Derating Curve

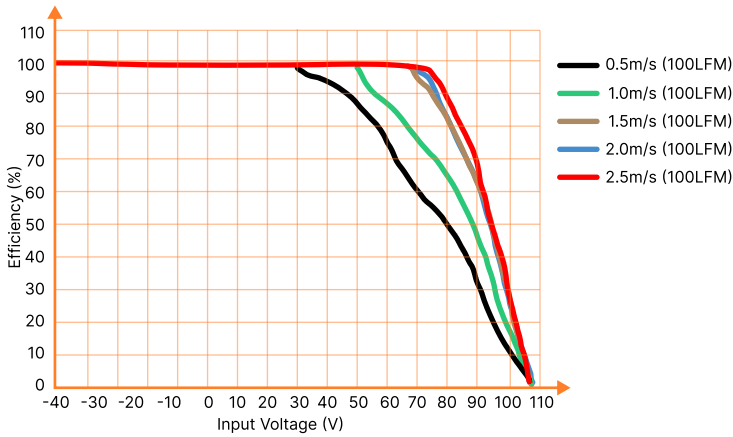

DCWF1D15HB-250W
Temperature Derating Curve

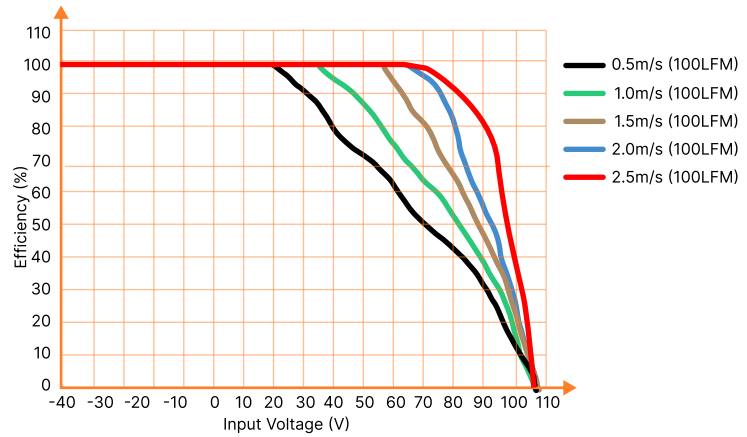

DCWF1D24HB-250W
Temperature Derating Curve

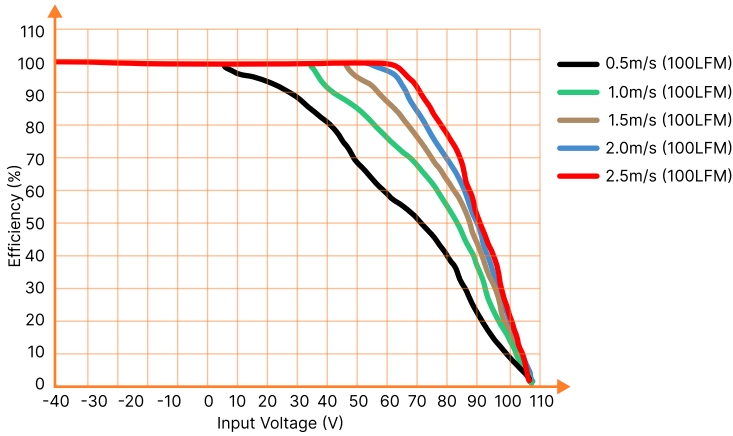

DCWF1D48HB-250W
Temperature Derating Curve

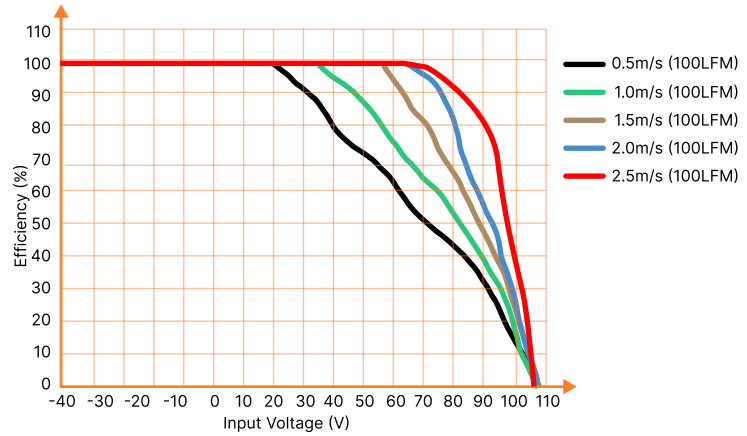

DCWF1D54HB-250W
Temperature Derating Curve

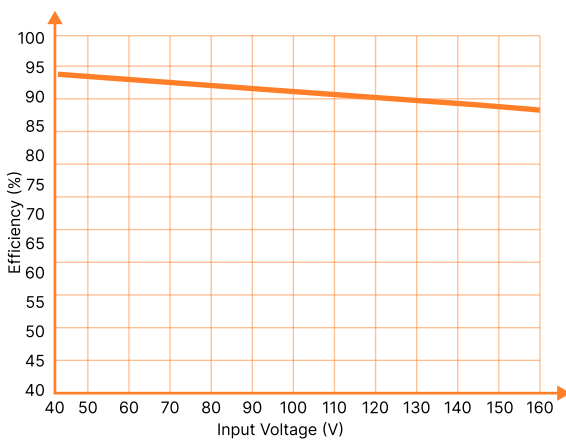

DCWF1D12HB-250W
Efficiency Vs Input Voltage (Full Load)

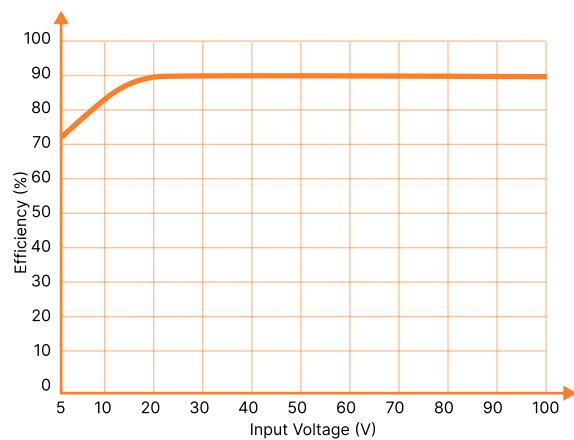

DCWF1D12HB-250W
Efficiency Vs Output Load (Vin=110V)

CIRCUIT DESIGN AND APPLICATION

1. Remote Sense Application

1. Remote Sense Connection if not used

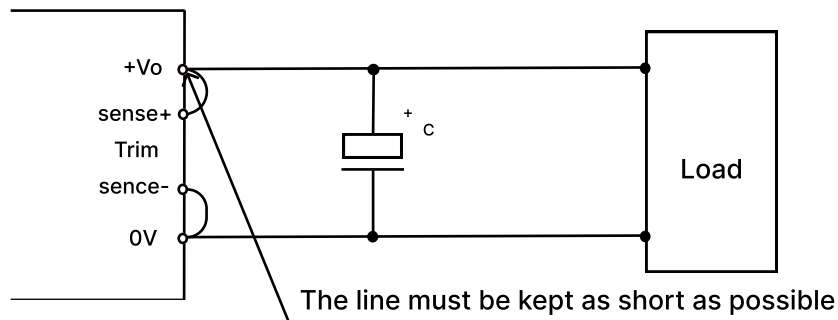

Notes :

1. If the sense function is not used for remote regulation the user must connect the +Sense to + Vo and -Sense to 0V at the DC-DC converter pins and will compensate for voltage drop across pins only.
2. The connections between Sense lines and their respective power lines must be kept as short as possible, otherwise they may be picking up noise, interference and/or causing unstable operation of the power module.

2. Remote Sense Connection used for Compensation

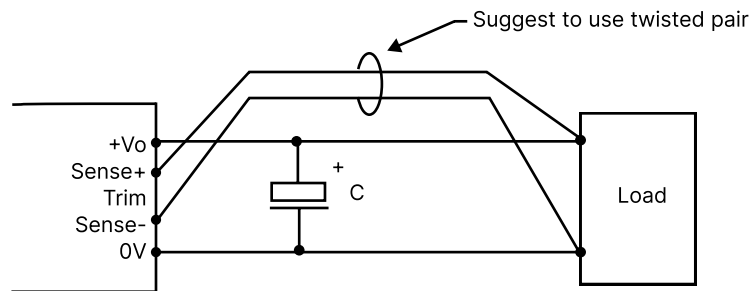

Notes:

1. Using remote sense with long wires may cause unstable output, please contact technical support if long wires must be used.
2. PCB-tracks or cables/wires for Remote Sense must be kept as short as possible. Twisted pair or shielded wires are suggested for remote compensation and must be kept as short as possible.
3. We recommend using adequate cross section for PCB-track layout and/or cables to connect the power supply module to the load in order to keep the voltage drop below 0.3V and to make sure the power supply's output voltage remains within the specified range.
4. Note that large wire impedance may cause oscillation of the output voltage and/or increased ripple. Consult technical support or factory for further advice of sense operation.

1. Ripple & noise

All the DC-DC converters of this series are tested before delivery using the recommended circuit shown in Fig. 1

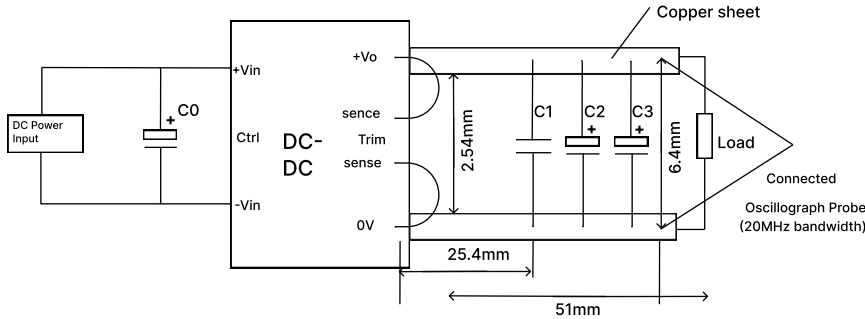

Capacitors Output Voltage Value	C0(μF)	C1	C2(μF)	C3(μF)
5VDC	100μF aluminum Electrolytic capacitor (Voltage ≥200V)	105K/50V ceramic capacitor	10μF/35V tantalum capacitor	220μF/35V electrolytic capacitor
12VDC				
15VDC				
24VDC				
40VDC				
48VDC				
54VDC	105K/100V ceramic capacitor	-	220μF/100V electrolytic capacitor	

2. Typical Application

We recommended using RHENXV's EMC circuit, otherwise please ensure that at least a 100μF electrolytic capacitors is connected at the input in order to ensure adequate voltage surge suppression and protection.

Input and/or output ripple can be further reduced by appropriately increasing the input & output capacitor values C_{in} and C_{out} and/or by selecting capacitors with a low ESR (equivalent series resistance). Also make sure that the capacitance is not exceeding the specified max. capacitive load value of the product.

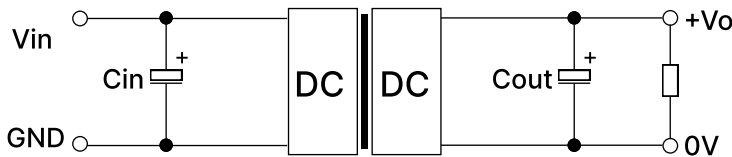

Recommended Capacitive Load Values

Vout (VDC)	Cin (μF)	Cout (μF)
5V/12V/15V 24V/40V/ 48V/54V	100 μF/200V	220μF/63V

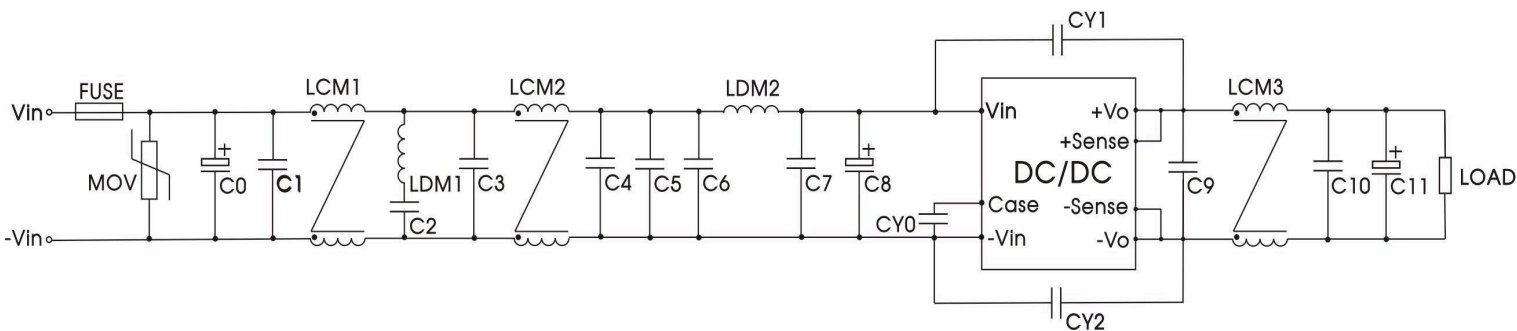

Components	Value	Components	Value
FUSE	Choose according to actual inputcurrent	LCM2	/
MOV	S20K130 (Varistor)	LCM3	/
C0	150µF/200V electrolytic capacitor	LDM1	0.47uH Shielded inductor
C8	100µF/200V electrolytic capacitor	LDM2	2.2uH Shielded inductor
C11	220µF/63V electrolytic capacitor	CY0	1nF/400VAC Y1 safety capacitor
C1/C2/C3/C4/C5/ C6/C7/C9/C10	2.2µF/ 250V ceramic capacitor	CY1	2.2nF/400VAC Y1 safety capacitor
LCM1	/	CY2	1nF/400VAC Y1 safety capacitor

3. Trim Function for Output Voltage Adjustment (open if unused)

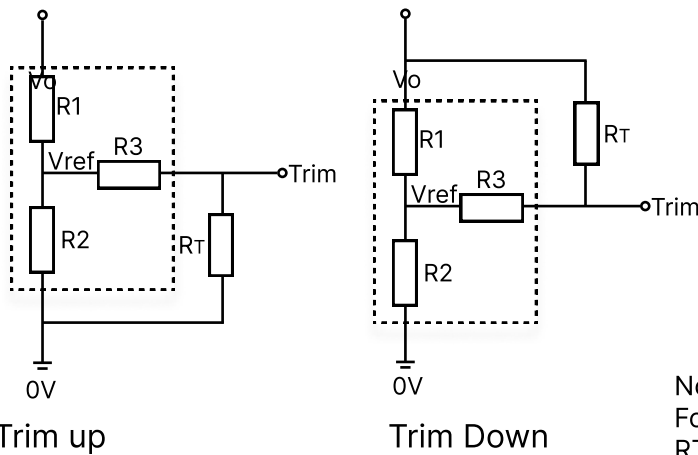

The Calculation formula for trim resistance

$$\text{Trim up: } R_T = \frac{aR_2}{R_2 - a} - R_3 \quad a = \frac{V_{ref}}{V_o' - V_{ref}} R_1$$

$$\text{Trim down: } R_T = \frac{aR_1}{R_1 - a} - R_3 \quad a = \frac{V_o' - V_{ref}}{V_{ref}} R_2$$

Note :
For R1, R2, R3 and Vref values refer to table 1.
RT = Trim Resistor value; .a = self-defined parameter
Vo' = desired output voltage

Trim up

Trim Down

TRIM resistor connection (dashed line shows internal resistor network)

Vout(V)	5(VDC)	12(VDC)	15(VDC)	24(VDC)	40(VDC)	48(VDC)	54(VDC)
R1(KΩ)	2.92	11	14.49	24.87	48.37	58.69	60.44
R2(KΩ)	2.87	2.87	2.87	2.87	3.21	3.21	2.91
R3(KΩ)	12	17.8	20	20	20	20	17.8
Vref(V)	2.495	2.495	2.495	2.495	2.495	2.495	2.495

DIMENSIONS AND INSTALLATION

DCWF1D_HB-250W (without heatsink)

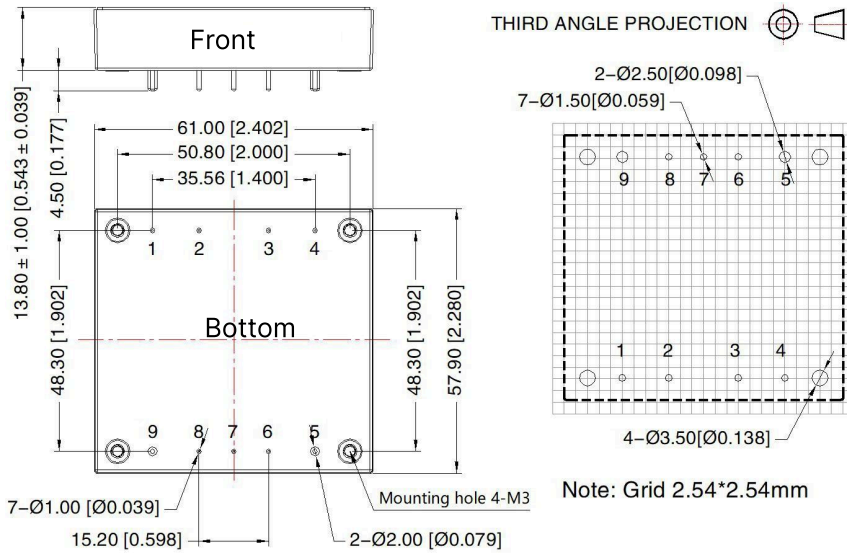

Pin Function Table

Pin	Function	Pin	Function
1	+Vin	6	Sense -
2	Ctrl	7	Trim
3	Case	8	Sense +
4	-Vin	9	+Vo
5	0V		

Unit: mm[inch]
 PIN 1,2,3,4,6,7,8's diameter: 1.00[0.039]
 PIN 5,9's diameter: 2.00[0.079]
 PIN Diameter Tolerances: ±0.10[±0.004]
 General Tolerances: ±0.50[±0.020]
 Mounting hole screwing torque: Max 0.4 N-m

DCWF1D_HB-250WH (with heatsink)

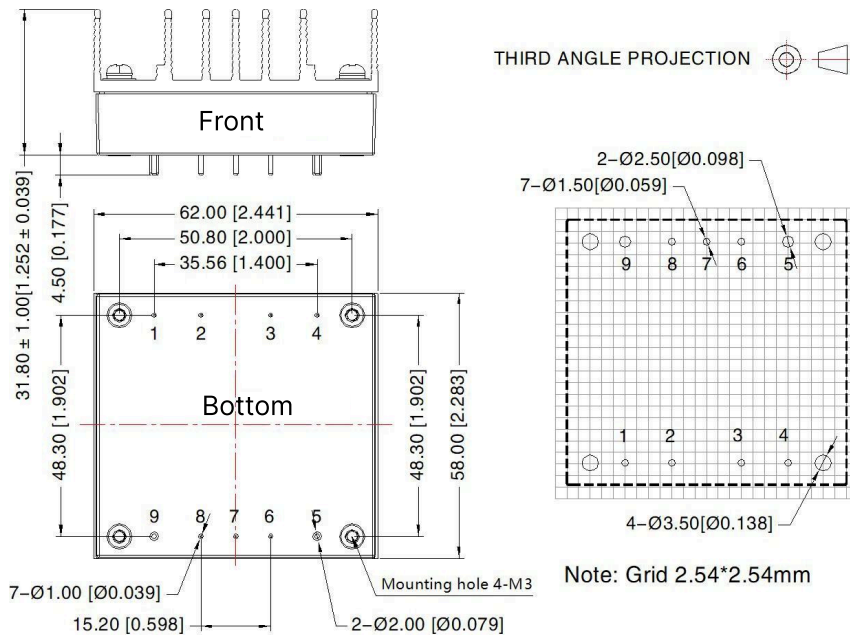

Pin Function Table

Pin	Function	Pin	Function
1	+Vin	6	Sense -
2	Ctrl	7	Trim
3	Case	8	Sense +
4	-Vin	9	+Vo
5	0V		

Unit: mm[inch]
 PIN 1,2,3,4,6,7,8's diameter: 1.00[0.039]
 PIN 5,9's diameter: 2.00[0.079]
 PIN Diameter Tolerances: ±0.10[±0.004]
 General Tolerances: ±0.50[±0.020]
 Mounting hole screwing torque: Max 0.4 N-m

DIMENSIONS AND INSTALLATION

DCWF1D05/12/15HB-250WST (without heatsink)

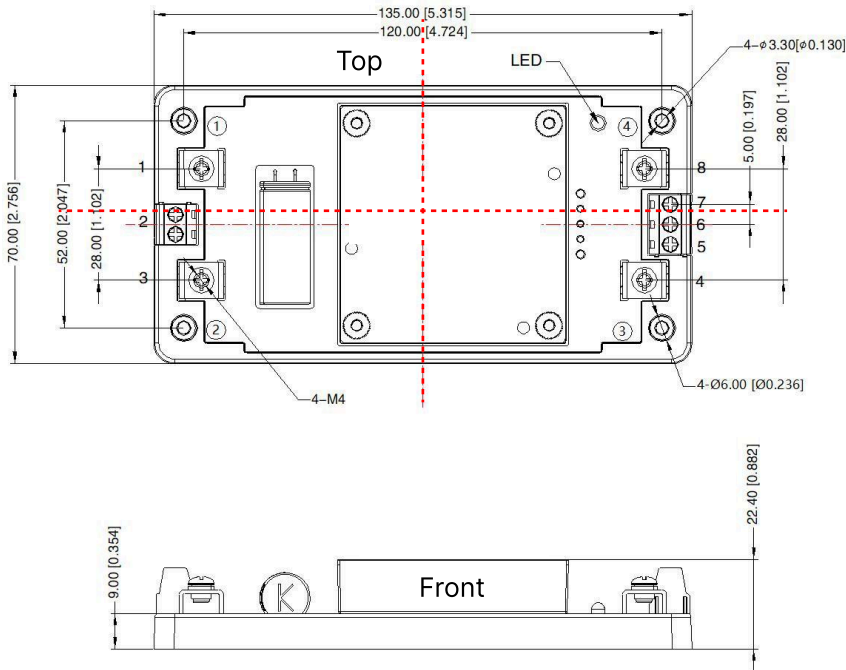

THIRD ANGLE PROJECTION 
Pin Function Table

Pin	Function	Pin	Function
1	+Vin	6	Trim
2	Ctrl	7	Sense +
3	-Vin	8	+Vo
4	0V		
5	Sense -		

Position	Screw Spec	Torque (max)
①-④	M3	0.4N.m

Unit: mm[inch]
 Wire range: PIN 1,3,4,8 8AWG
 PIN 2,5-7 24~12 AWG
 Tightening torque: PIN 1,3,4,8 M4, Max 0.9N.m
 PIN 2,5-7 M3, Max 0.4 N.m
 General Tolerances: ±1.00[±0.039]

DCWF1D24/40/48/54HB-250WST (without heatsink)

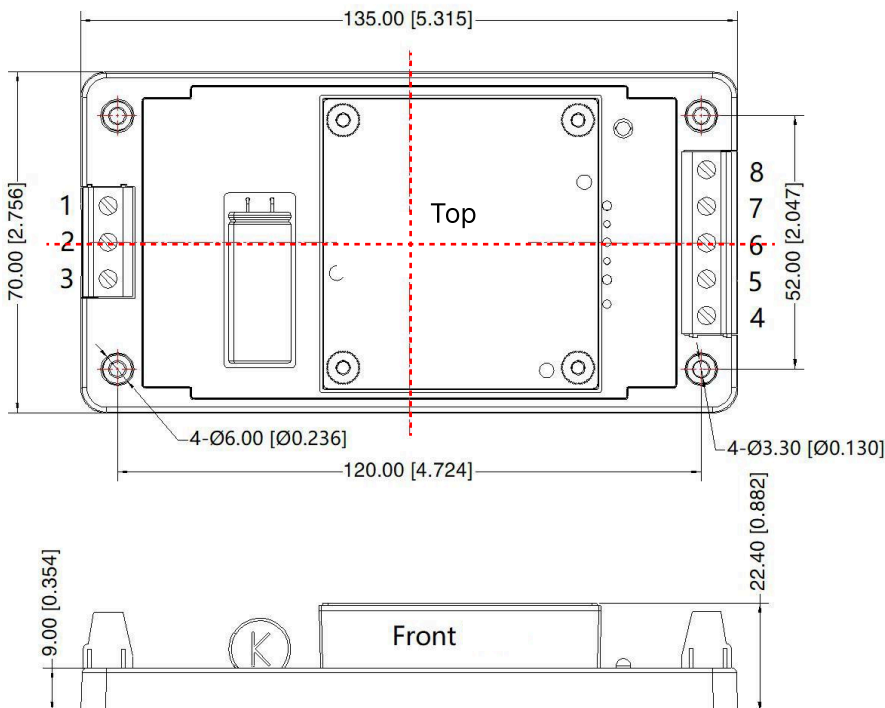

THIRD ANGLE PROJECTION 

Pin Function Table

Pin	Function	Pin	Function
1	+Vin	6	Trim
2	Ctrl	7	Sense +
3	-Vin	8	+Vo
4	0V		
5	Sense -		

Unit: mm[inch]
 PIN 1,2,3,4,6,7,8's diameter: 1.00[0.039]
 PIN 5,9's diameter: 2.00[0.079]
 PIN Diameter Tolerances: ±0.10[±0.004]
 General Tolerances: ±0.50[±0.020]
 Mounting hole screwing torque: Max 0.4 N-m

DIMENSIONS AND INSTALLATION

DCWF1D05/12/15HB-250WHST (with heatsink)

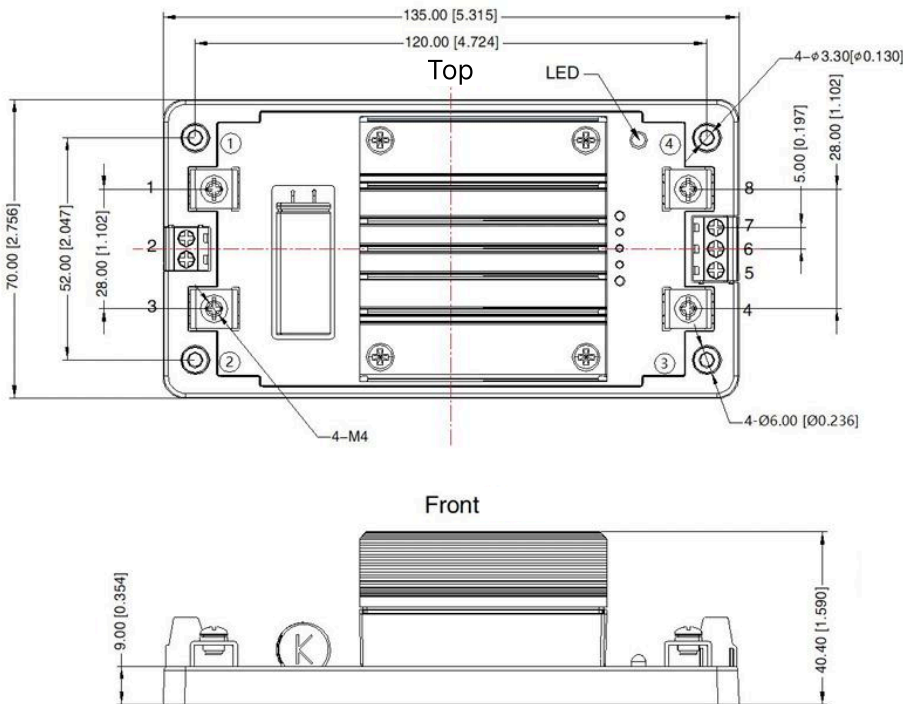

THIRD ANGLE PROJECTION 
Pin Function Table

Pin	Function	Pin	Function
1	+Vin	6	Trim
2	Ctrl	7	Sense +
3	-Vin	8	+Vo
4	0V		
5	Sense -		

Position	Screw Spec	Torque (max)
①-④	M3	0.4N.m

Unit: mm[inch]
 Wire range: PIN 1,3,4,8 8AWG
 PIN 2,5-7 24~12 AWG
 Tightening torque: PIN 1,3,4,8 M4, Max 0.9N.m
 PIN 2,5-7 M3, Max 0.4 N.m
 General Tolerances: $\pm 1.00[\pm 0.039]$

DCWF1D24/40/48/54HB-250WST (with heatsink)

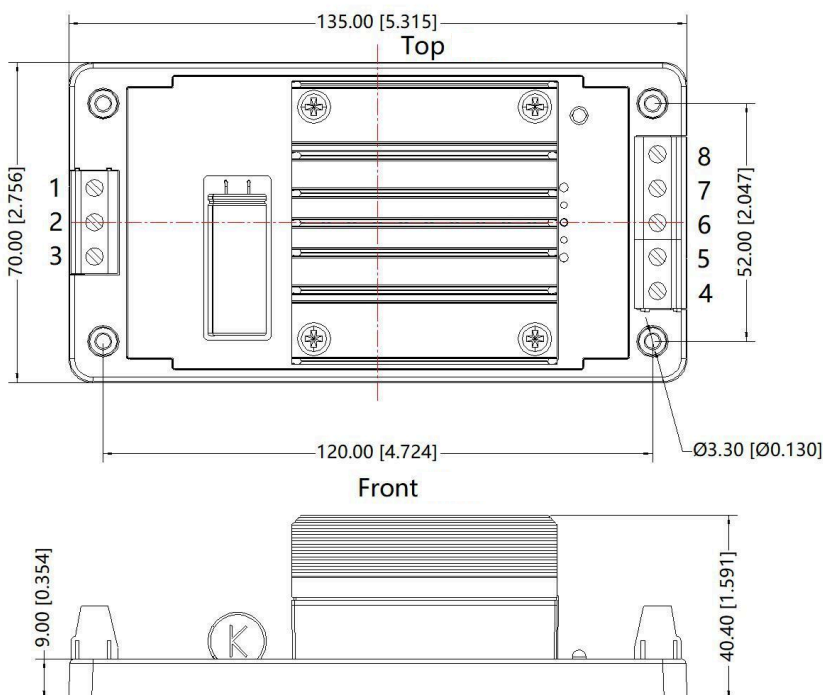

THIRD ANGLE PROJECTION 
Pin Function Table

Pin	Function	Pin	Function
1	+Vin	6	Trim
2	Ctrl	7	Sense +
3	-Vin	8	+Vo
4	0V		
5	Sense -		

Unit: mm[inch]
 Wire range: PIN 1,3,4,8 8AWG
 PIN 2,5-7 24~12 AWG
 Tightening torque: PIN 1,3,4,8 M4, Max 0.9N.m
 PIN 2,5-7 M3, Max 0.4 N.m
 General Tolerances: $\pm 1.00[\pm 0.039]$

Note:

1. If the product works under the minimum required load, it cannot guarantee that the performance of the product complies with all the performance indicators in this manual;
2. The maximum capacitive load is tested under the input voltage range and full load condition;
3. Unless otherwise stated, all indexes in this manual are measured at $T_a=25^{\circ}\text{C}$, humidity $<75\%RH$, nominal input voltage and rated output load;
4. All index testing methods in this manual are based on the enterprise standards of the company;
5. Our company can provide product customization, specific needs can directly contact our technical staff;