

### DCWB\_LD-30W Series



CE Report RoHS



### FEATURES

- Wide input voltage range (4:1)
- High efficiency up to 90%
- No-load power consumption as low as 0.14W
- Isolation voltage :1.5K VDC
- Input under-voltage protection, output short circuit, over-current protection
- Operating temperature range: -40°C To +80°C
- 3 Years Warranty

### DESCRIPTION

DC-DC Module Power Supply, Wide Voltage Input, Power 30W, Isolated, Regulated, Single Output, DIP Packaging.

### MODEL NUMBERING

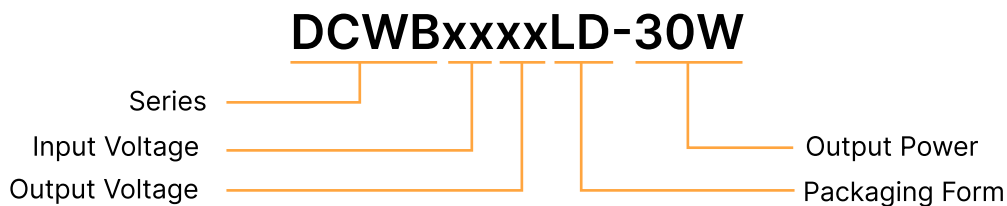

### SELECTION GUIDE

Product Model	Input Voltage Standard Value(range)	Output Voltage (Vdc)	Output Current (mA) (Max./Min.)	Efficiency % (Min./Typ.)	Maximum capacitive load ( $\mu$ F)
DCWB2403LD-30W	24VDC (9-36)	3.3	6000/0	83/85	10000
DCWB2405LD-30W		5	6000/0	84/86	10000
DCWB2409LD-30W		9	3333/0	86/88	4700
DCWB2412LD-30W		12	2500/0	88/90	2700
DCWB2415LD-30W		15	2000/0	88/90	1680
DCWB2424LD-30W		24	1250/0	88/90	680

Note: Use suffix "ST" for screw terminal, suffix "DR" for DIN-Rail

Product Model	Input Voltage Standard Value(range)	Output Voltage (Vdc)	Output Current (mA) (Max./Min.)	Efficiency % (Min./Typ.)	Maximum capacitive load ( $\mu$ F)
DCWB4803LD-30W	48VDC (18-75)	3.3	6000/0	84/86	10000
DCWB4805LD-30W		5	6000/0	85/87	10000
DCWB4812LD-30W		12	2500/0	86/88	2700
DCWB4815LD-30W		15	2000/0	87/89	1680
DCWB4824LD-30W		24	1250/0	85/87	680

Note: Use suffix "ST" for screw terminal, suffix "DR" for DIN-Rail

## INPUT CHARACTERISTICS

Parameter	Conditions	Min.	Typ.	Max.	Units	
Input Current (full load /no load)	24VDC nominal input series, nominal input voltage	3.3V Output	--	971/60	994/100	mA
		5V Output	--	1453/60	1488/100	mA
		Others	--	1420/6	1488/16	mA
	48VDC nominal input series, nominal input voltage	3.3V Output	--	480/20	491/30	mA
		5V Output	--	718/20	735/35	mA
		Others	--	710/5	744/10	mA
Reflected Ripple Current	Nominal inputvoltage	--	40	--	mA	
SurgeVoltage(1sec.max.)	Nominal voltage input@24VDC	-0.7	--	50	VDC	
	Nominal voltage input@48VDC	-0.7	--	100	VDC	
Starting voltage	Nominal voltage input@24VDC	--	--	9	VDC	
	Nominal voltage input@48VDC	--	--	18	VDC	
Input Under-voltage Protection	Nominal voltage input@24VDC	5.5	6.5	--	VDC	
	Nominal voltage input@48VDC	12.0	15.5	--	VDC	
Start-upTime	Nominal Input Voltage & Constant Resistance Load	--	10	--	ms	
Ctrl*	Module On	Ctrl pin open or pulled high (3.5-12VDC)				
	Module off	Ctrl pin pulled low to GND (0-1.2VDC)				
	Input current when off	--	5	8	mA	
Input filter		Pi filter				

Remarks: This product does not support hot plug

## OUTPUT CHARACTERISTICS

Parameter	Operating Conditions		Min.	Typ.	Max.	Units
Output Voltage Accuracy	5%-100% load		--	±1	±3	%
	0%-5% load		--	±1	±5	%
Linear Regulation	Input voltage variation from low to high at full load	Vo	--	±0.2	±0.5	%
Load Regulation	5 %-100 % load	Vo	--	±0.5	±1	%
Dynamic Response Recovery Time	25% load step change, nominal input voltage		--	300	500	µs
Dynamic Response Step Deviation	25% load step change, nominal input voltage	3.3V/5V output	--	±5	±8	%
		Others	--	±3	±5	%
Temperature Drift Coefficient	Full load		--	--	±0.03	%/°C
Ripple & Noise*	20MHz bandwidth, nominal input voltage, 100% load		--	50	100	mVp-p
Trim	Input voltage range		90	--	110	%Vo
Over-voltage Protection			110	--	160	%Vo
Over-current Protection			110	--	190	%Io
Short-circuit Protection			Hiccup, continuous, self-recovery			

Note: \*By measuring method is used for Ripple and Noise test, please refer to Fig. 2. for recommended circuit.

## GENERAL CHARACTERISTIC

Parameter	Operating Conditions	Min.	Typ.	Max.	Units
Isolation	Input/output-Case Electric Strength Test for 1 minute with a leakage current of 1mA max.	1500	--	--	VDC
Insulation Resistance	Input-output resistance at 500VDC/60sec	1000	--	--	MΩ
Isolation Capacitance	Input-output capacitance at 100KHz/0.1V	--	2000	--	pF

Parameter	Operating Conditions	Min.	Typ.	Max.	Units
Operating Temperature	See Fig.1, Fig.2, Fig.3 and Fig.4	-40	--	+80	°C
Storage Temperature		-55	--	+125	°C
Storage Humidity	Non-condensing	5	--	95	%RH
Pin Soldering Resistance °C Temperature	Soldering spot is 1.5mm away from case for 10 seconds	--	--	+300	°C
Vibration		IEC/EN61373 - Category 1, Grade B			
Switching Frequency *	PWM mode	--	300	--	KHz
MTBF	MIL-HDBK-217F@25°C	1000	--	--	Khours

Note:\* Switching frequency is measured at full load. The module reduces the switching frequency for light load (below 50%) efficiency improvement

## PHYSICAL CHARACTERISTICS

Parameter	Conditions
Case Material	Aluminum alloy
Overall dimensions	50.80 × 25.40 × 11.80 mm
Weight	27.5g
Cooling Method	Free air convection

## EMC CHARACTERISTICS

Parameter	Category	Content
Emissions	CE	CISPR32/EN55032 CLASS A (without external components)/ CLASS B (see Fig.6-② for recommended circuit)
	RE	CISPR32/EN55032 CLASS A (without external components)/ CLASS B (see Fig.6-② for recommended circuit)
Immunity	ESD	IEC/EN61000-4-2 Contact ±4kV perf. Criteria B
	RS	IEC/EN61000-4-3 10V/m perf. Criteria A
	EFT	IEC/EN61000-4-4 ±2kV (see Fig.6-① for recommended circuit) perf. Criteria B
	Surge	IEC/EN61000-4-5 line to line ±2kV (see Fig.6-① for recommended circuit) perf. Criteria B
	CS	IEC/EN61000-4-6 3 Vr.m.s perf. Criteria A

### PRODUCT CHARACTERISTIC CURVE

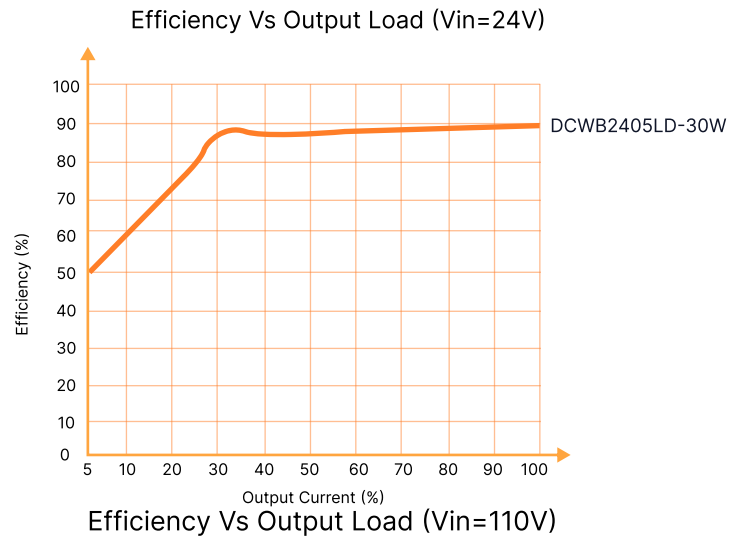
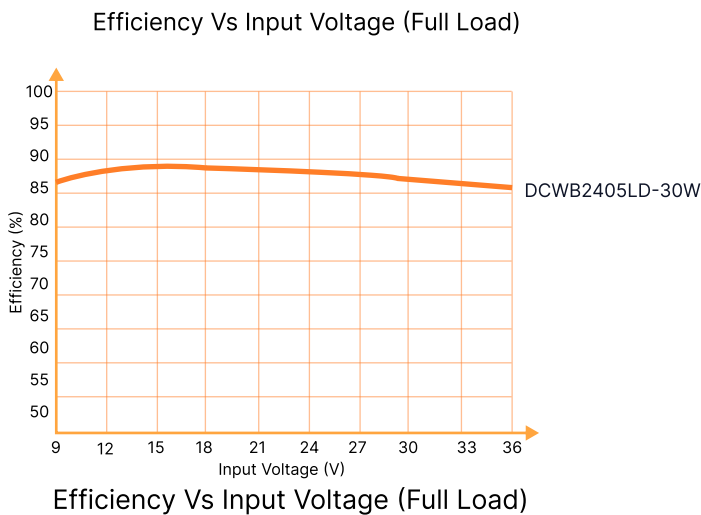
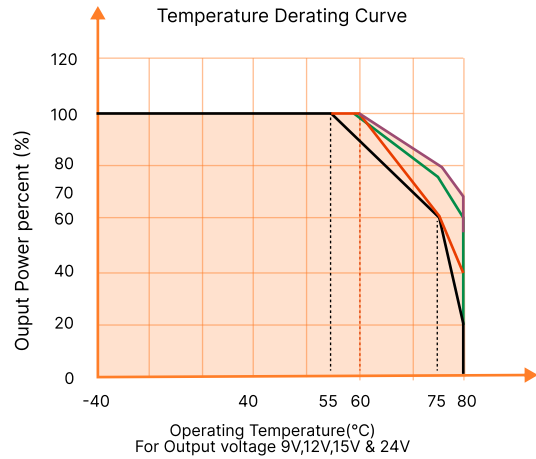
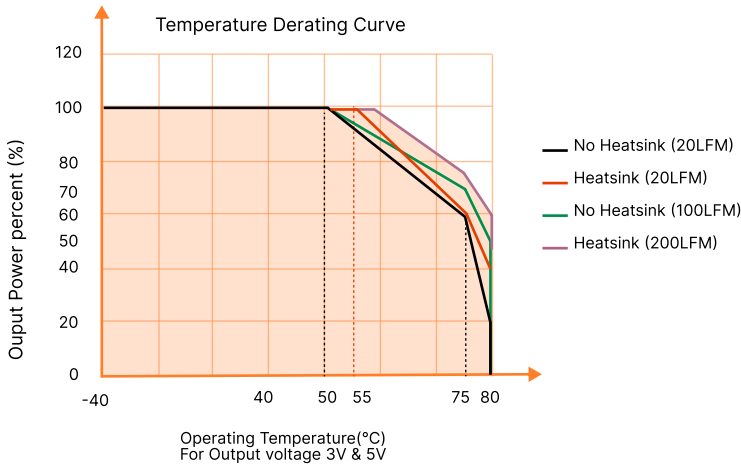

### CIRCUIT DESIGN AND APPLICATION

#### 1. Typical application

All the DC/DC converters of this series are tested before delivery using the recommended circuit shown in Fig. 5. Input and/or output ripple can be further reduced by appropriately increasing the input & output capacitor values  $C_{in}$  and  $C_{out}$  and/or by selecting capacitors with a low ESR (equivalent series resistance). Also make sure that the capacitance is not exceeding the specified max. capacitive load value of the product.

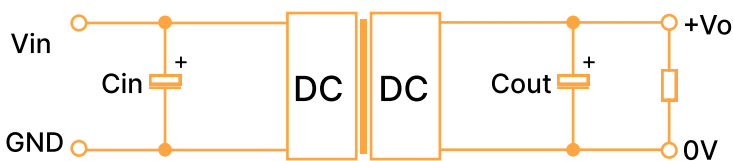

Fig.5

Table 1: Recommended Capacitive Load Values

Output Voltage (VDC)	$C_{out}(\mu F)$	$C_{in}(\mu F)$
3.3/5/9	220	100
12/15/24	100	

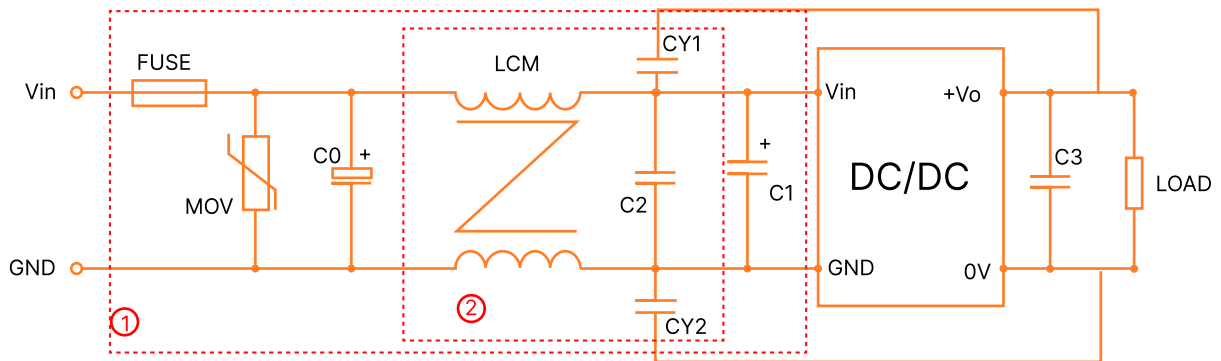
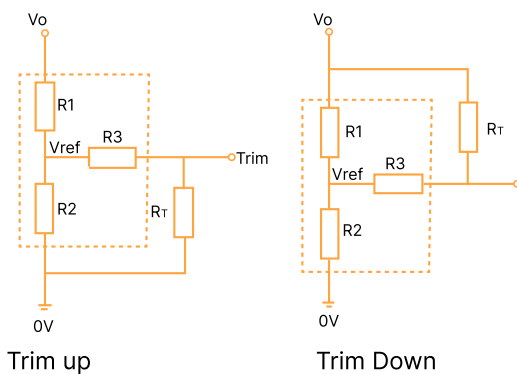

Fig. 6

Notes: We use Part ① in Fig. 6 for immunity and part ② for emissions test. Selecting based on needs.

Model	Vin:24VDC	Vin:48VDC
FUSE	Choose according to actual input current	
MOV	S20K30	S14K60
C0	680μF/50V	330μF/100V
C1	330μF/50V	330μF/100V
C2	4.7μF/50V	2.2μF/100V
C3	Refer to the Cout in Fig.5	
LCM	1mH	
CY1/CY2	1nF/2kV	

### 3. Trim Function for Output Voltage Adjustment (open if unused)



Trim resistor connections (dashed line shows internal resistor network)

Calculating Trim resistor values:

$$\text{Trim up: } R_T \frac{aR_2}{R_2-a} - R_3 \quad a = \frac{V_{ref}}{V_o' - V_{ref}} R_1$$

$$\text{Trim down: } R_T \frac{aR_1}{R_1-a} - R_3 \quad a = \frac{V_o' - V_{ref}}{V_{ref}} R_2$$

$R_T$  is Trim resistance  
 $a$  is a self-defined parameter,  
 $V_o'$  = desired output voltage

Vout(VDC)	R1(KΩ)	R2(KΩ)	R3(KΩ)	Vref(V)
3.3	4.801	2.87	12.4	1.24
5	2.883	2.87	10	2.5
9	7.500	2.87	15	2.5
12	11.000	2.87	15	2.5
15	14.494	2.87	15	2.5
24	24.872	2.87	17.8	2.5

**OVERALL DIMENSIONS AND PIN FUNCTIONS**

**DCWB\_LD-30W (without heatsink)**

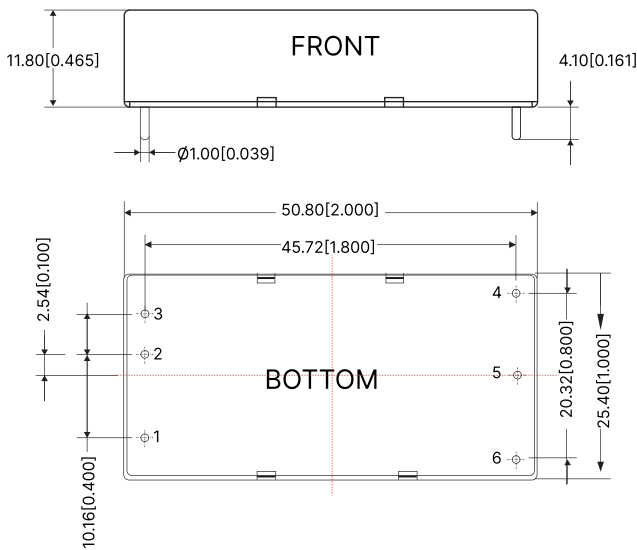

Note:  
Unit: mm[inch]  
Pin diameter tolerances:  $\pm 0.10$  [ $\pm 0.004$ ]  
General tolerances:  $\pm 0.50$  [ $\pm 0.020$ ]

THIRD ANGLE PROJECTION 

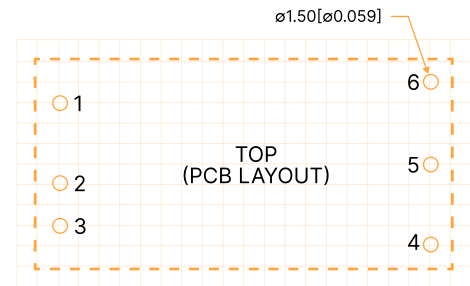

Note: Grid 2.54\*2.54

Table 1: Pin Function Table

Pin	Function
1	Ctrl
2	GND
3	Vin
4	+Vo
5	0V
6	Trim

**DCWB\_LD-30WH (with heatsink)**

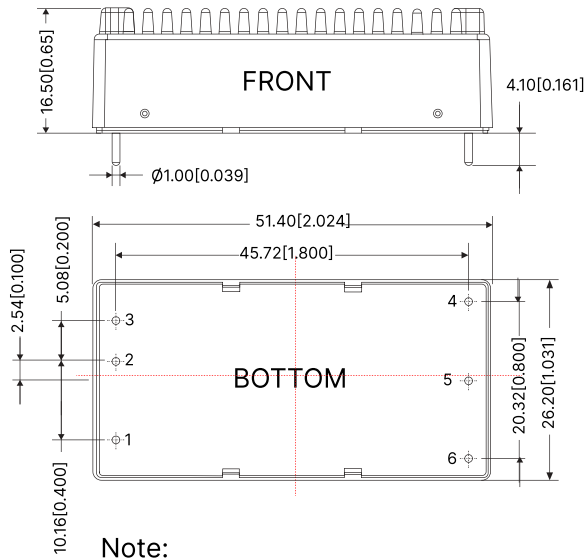

Note:  
Unit: mm[inch]  
Pin diameter tolerances:  $\pm 0.10 [\pm 0.004]$   
General tolerances:  $\pm 0.50 [\pm 0.020]$

THIRD ANGLE PROJECTION 

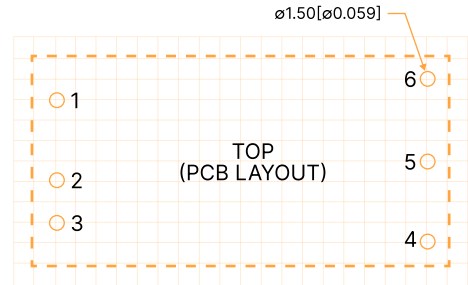

Note: Grid 2.54\*2.54

Table 2: Pin Function Table

Pin	Function
1	Ctrl
2	GND
3	Vin
4	+Vo
5	0V
6	Trim

**DCWB\_LD-30WST (without heatsink)**

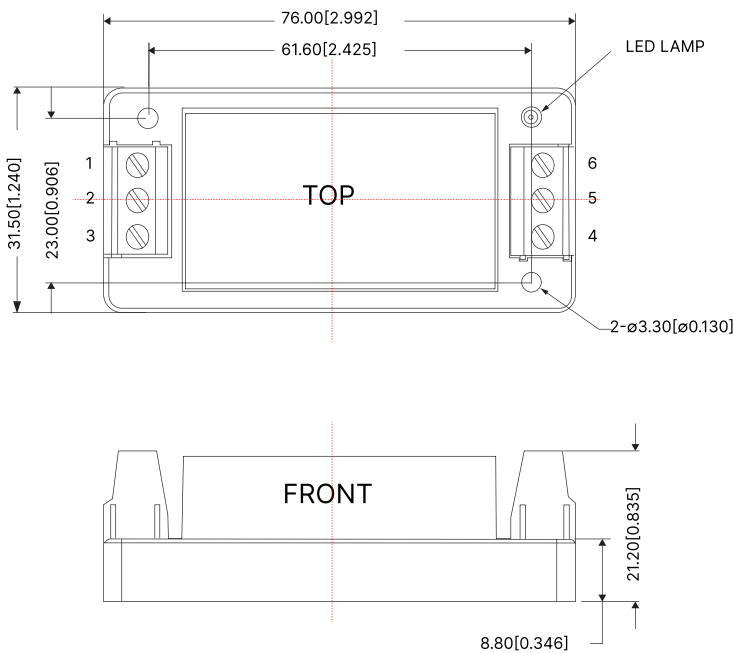

THIRD ANGLE PROJECTION 

Table 3: Pin Function Table

Pin	Function
1	Ctrl
2	GND
3	Vin
4	+Vo
5	0V
6	Trim

Note:  
Unit: mm[inch]  
Wide range: 24-12 AWG  
Tightening torque: Max 0.4 N-m  
General tolerances:  $\pm 1.00 [\pm 0.039]$

### DCWB\_LD-30WHST (with heatsink)

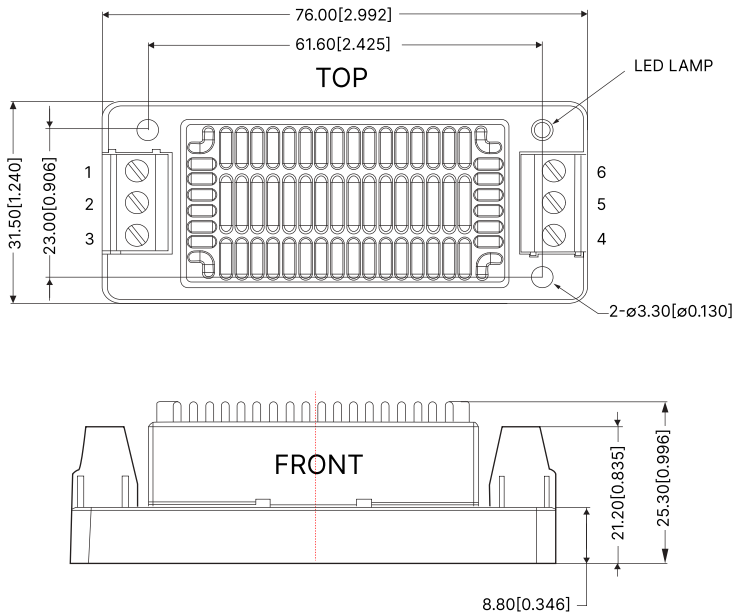

THIRD ANGLE PROJECTION 

Table 4: Pin Function Table

Pin	Function
1	Ctrl
2	GND
3	Vin
4	+Vo
5	0V
6	Trim

Note:

Unit: mm[inch]

Wide range: 24-12 AWG

Tightening torque: Max 0.4 N-m

General tolerances:  $\pm 1.00$  [ $\pm 0.039$ ]

### DCWB\_LD-30WDR (without heatsink)

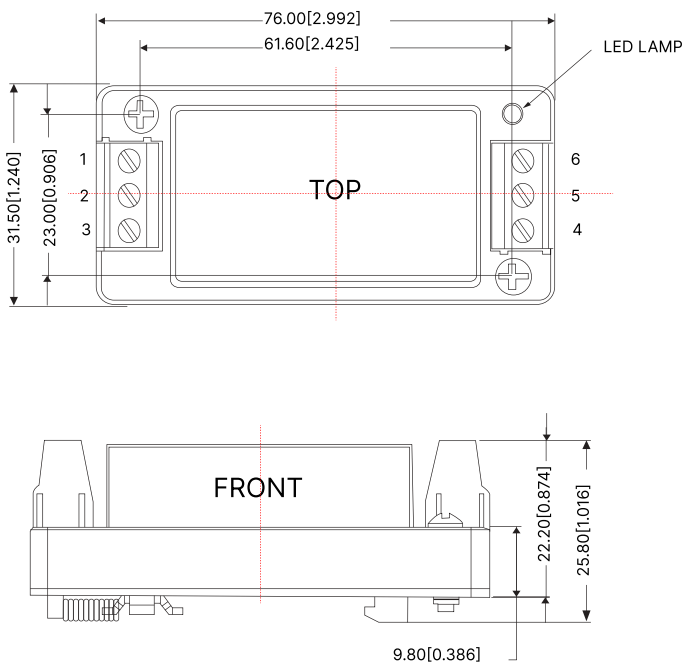

THIRD ANGLE PROJECTION 

Table 5: Pin Function Table

Pin	Function
1	Ctrl
2	GND
3	Vin
4	+Vo
5	0V
6	Trim

Note:

Unit: mm[inch]

Mounting Rail: TS35

Wide range: 24-12 AWG

Tightening torque: Max 0.4 N-m

General tolerances:  $\pm 1.00$  [ $\pm 0.039$ ]

**DCWB\_LD-30WHDR (with heatsink)**

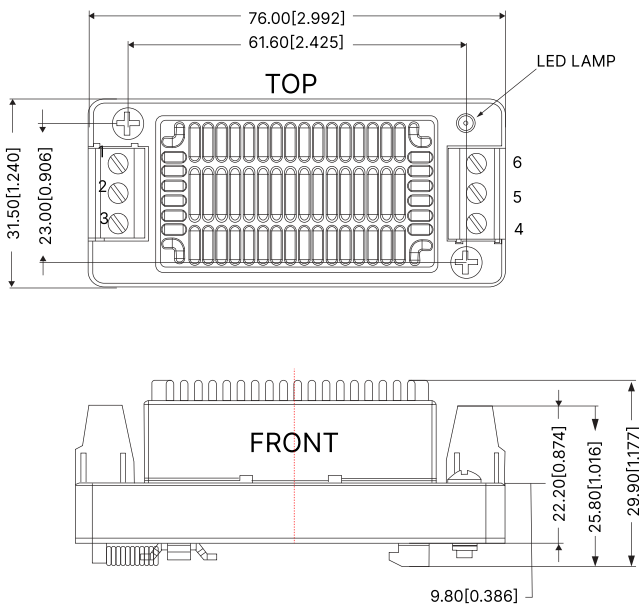

THIRD ANGLE PROJECTION

**Table 6: Pin Function Table**

Pin	Function
1	Ctrl
2	GND
3	Vin
4	+Vo
5	0V
6	Trim

Note:  
Unit: mm[inch]  
Mounting Rail: TS35  
Wide range: 24-12 AWG  
Tightening torque: Max 0.4 N-m  
General tolerances:  $\pm 1.00$  [ $\pm 0.039$ ]

**NOTE**

Note:

1. For additional information on Product Packaging please refer to [www.henxv.com](http://www.henxv.com)
2. Recommended used in more than 10% load, if the load is lower than 10%, then the ripple index of the product may exceed the specification, but does not affect the reliability of the product;
3. If the product is not operated within the required load range, the product performance cannot be guaranteed to comply with all parameters in the datasheet;
4. The maximum capacitive load offered were tested at input voltage range and full load;
5. Unless otherwise specified, parameters in this datasheet were measured under the conditions of  $T_a=25^{\circ}\text{C}$ , humidity<75%RH with nominal input voltage and rated output load;
6. All index testing methods in this datasheet are based on company corporate standards;
7. We can provide product customization service, please contact our technicians directly for specific information;