

### DCMB\_YD-15W Series



### FEATURES

- Wide voltage range input (2:1)
- Wide operating temperature range : -40°C To +105 °C
- Up to 91% efficiency
- Input under-voltage protection, Output short circuit, overcurrent, overload protection
- I/O isolation test voltage 1.5k VDC
- 3 Years Warranty

### DESCRIPTION

DC-DC Module Power Supply, Wide Voltage Input, Power 15W, Isolated, Regulated, Single Output, DIP Packaging

### MODEL NUMBERING

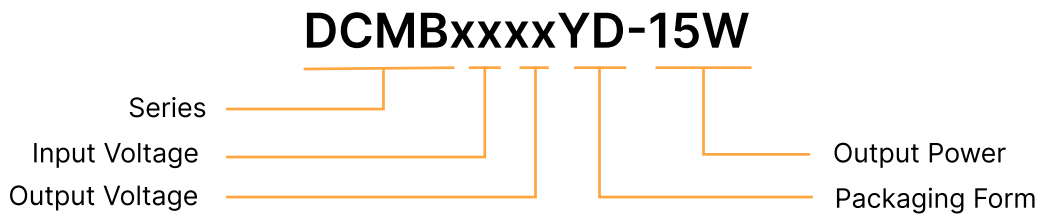

### SELECTION GUIDE

Product Model	Input Voltage Standard Value(range)	Output Voltage	Output Current (mA) (Max./Min.)	Efficiency % (Min./Typ.)	Maximum capacitive load ( $\mu$ F)
DCMB1203YD-15W	12VDC (9-18)	3.3	4000/0	86/88	4700
DCMB1205YD-15W		5	3000/0	88/90	4700
DCMB1212YD-15W		12	1250/0	88/90	1000
DCMB1215YD-15W		15	1000/0	89/91	820
DCMB1224YD-15W		24	625/0	89/91	270

Product Model	Input Voltage Standard Value(range)	Output Voltage	Output Current (mA) (Max./Min.)	Efficiency % (Min./Typ.)	Maximum capacitive load ( $\mu$ F)
DCMB2403YD-15W	24VDC (18-36)	3.3	4000/0	86/88	4700
DCMB2405YD-15W		5	3000/0	88/90	4700
DCMB2412YD-15W		12	1250/0	88/90	1000
DCMB2415YD-15W		15	1000/0	89/91	820
DCMB2424YD-15W		24	625/0	88/90	270
DCMB4803YD-15W	48VDC (36-75)	3.3	4000/0	86/88	4700
DCMB4805YD-15W		5	3000/0	88/90	4700
DCMB4812YD-15W		12	1250/0	89/91	1000
DCMB4815YD-15W		15	1000/0	89/91	820
DCMB4824YD-15W		24	625/0	89/91	270

## INPUT CHARACTERISTICS

Parameter	Operating Conditions	Min.	Typ.	Max.	Units	
Input Current (full load / no-load)	Nominal voltage input @12VDC	3.3VDC	--	1250/40	1280/65	mA
		5VDC	--	1389/40	1421/65	
		12VDC	--	1389/7	1421/22	
		15VDC	--	1374/7	1405/22	
		24VDC	--	1374/12	1405/2	

Parameter	Operating Conditions	Min.	Typ.	Max.	Units	
Input Current (full load / no-load)	Nominal voltage input @24VDC	3.3VDC	--	625/30	647/50	mA
		5VDC	--	695/30	711/50	
		12VDC	--	695/6	711/15	
		15VDC	--	687/6	703/15	
		24VDC	--	687/10	703/20	
	Nominal voltage input @48VDC	3.3VDC	--	313/15	320/30	mA
		5VDC	--	348/15	356/30	
		12VDC	--	344/3	352/11	
		15VDC	--	344/3	352/11	
		24VDC	--	344/3	352/11	
Input impulse voltage	Nominal voltage input@24VDC	-0.7	--	25	VDC	
	Nominal voltage input@48VDC	-0.7	--	50	VDC	
	Nominal voltage input@24VDC	-0.7	--	100	VDC	
Start-up Voltage	Nominal voltage input@24VDC	--	--	9	VDC	
	Nominal voltage input@48VDC	--	--	18	VDC	
	Nominal voltage input@24VDC	--	--	36	VDC	
Under-voltage Protection	Nominal voltage input@24VDC	5.5	6.5	--	VDC	
	Nominal voltage input@48VDC	12	15.5	--	VDC	
	Nominal voltage input@24VDC	26	30	--	VDC	
Remote control foot (Some models are applicable)	Module On	Ctrl pin open or pulled high (3.5-12VDC)				
	Module shutdown	Ctrl pin pulled low to GND(0-1.2VDC)				
	Input current during shutdown	--	02	07		mA
Input filter	PI type					

Remarks: This product does not support hot plug

**OUTPUT CHARACTERISTICS**

Parameter	Conditions	Min.	Typ.	Max.	Units	
Output voltage accuracy	0% -100% Load	--	±1	±3	%	
Linear regulation rate	Input voltage variation+/- 1%	--	±0.2	±0.5	%	
Load regulation rate	5%-100% load	--	±0.5	±1	%	
Transient Recovery Time	25% load step change, nominal input voltage	--	300	500	µs	
Transient Response Deviation		3.3V, 5V Output	--	±3	±7	%
		Others	--	±3	±5	
Ripple & Noise	20MHz bandwidth, 5%-100% load	--	50	100	mVp p	
Temperature drift coefficient	100% load	--	--	±0.03	%/°C	
Output over voltage protection	Full voltage range input	110	--	160	%Vo	
Output over current protection		110	150	190	%Io	
Short circuit protection		Hiccup, continuous, self-recovery				

Note: The Testing Method For Ripple And Noise Is The Parallel Line Testing Method.

**GENERAL CHARACTERISTIC**

Parameter	Conditions	Min.	Typ.	Max.	Units	
Isolation voltage	Input output, test time 1 minute, Leakage current less than 1 mA	1500	--	--	VDC	
	Input/output-case Electric Strength Test for 1 minute with a leakage current of 1mA max	1000	--	--	VDC	
Insulation resistance	Input output, Insulation voltage 500VDC	1000	--	--	MΩ	
Isolation capacitance	Input output, 100KHz/0.1V	--	2000	--	pF	
Working temperature	See Fig. 1	3.3V, 5V output	-40	--	+95	°C
		Others	-40	--	+105	

Parameter	Conditions	Min.	Typ.	Max.	Units	
Storage temperature		-55	--	+105	°C	
Storage humidity	Non condensing	05	--	95	%RH	
Soldering temperature resistance of pins	Soldering spot is 1.5mm away from case for 10 seconds	--	--	+300	°C	
	Wave soldering, 10 seconds	255	260	265		
Switching frequency	PWM mode	3.3V, 5V output	--	300	--	kHz
		Others	--	270	--	
Mean time between failures 【MTBF】	MIL HDBK-217F@25°C	1000	--	--	kHours	
Vibration		10-150Hz, 5G, 0.75mm. alongX, YandZ				

## PHYSICAL CHARACTERISTICS

Parameter	Conditions
Housing material	Aluminum alloy
Overall dimensions	25.40 × 25.40 × 11.70mm
Weight	15g(Typ.)
Cooling mode	Natural air cooling

## EMC CHARACTERISTICS

Parameter	Category	Content	
EMI	Conductive disturbance	CISPR32/EN55032 CLASS A (Bare machine) CLASS B (Recommended circuit)	
	Radiation disturbance	CISPR32/EN55032 CLASS A (Bare machine) CLASS B (Recommended circuit)	
EMS	Electrostatic discharge	IEC/EN61000-4-2 Contact ±6kV, Air ±8kV	perf. Criteria B
	Radiated Immunity	IEC/EN61000-4-3 10V/m	perf. Criteria A
	Pulse group Immunity	IEC/EN61000-4-4 ±2kV (see Fig.3-① for recommended circuit)	perf. Criteria A
	Surge Immunity	IEC/EN61000-4-5 line to line ±2kV (see Fig.3-① for recommended circuit)	perf. Criteria B
	Conducted disturbance immunity	IEC/EN61000-4-6 3 Vr.m.s	perf. Criteria A

PRODUCT CHARACTERISTIC CURVE

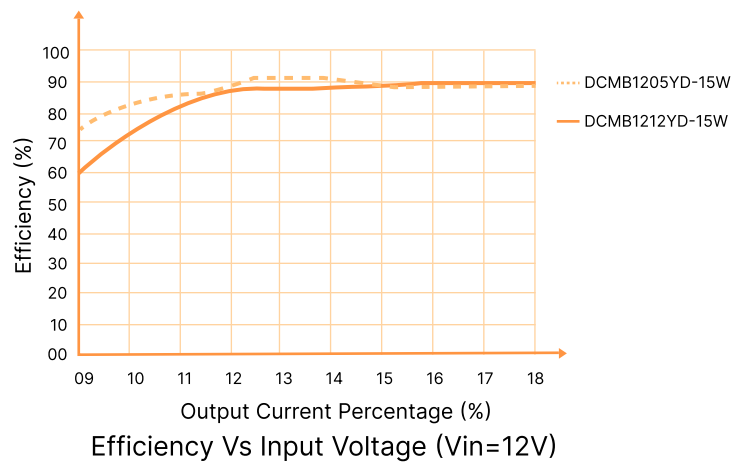
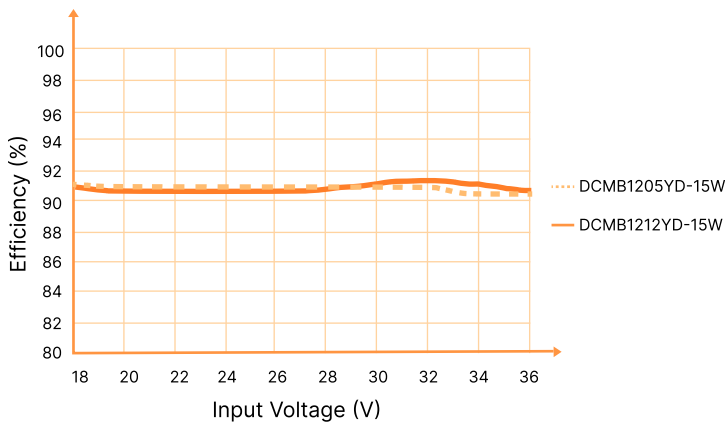
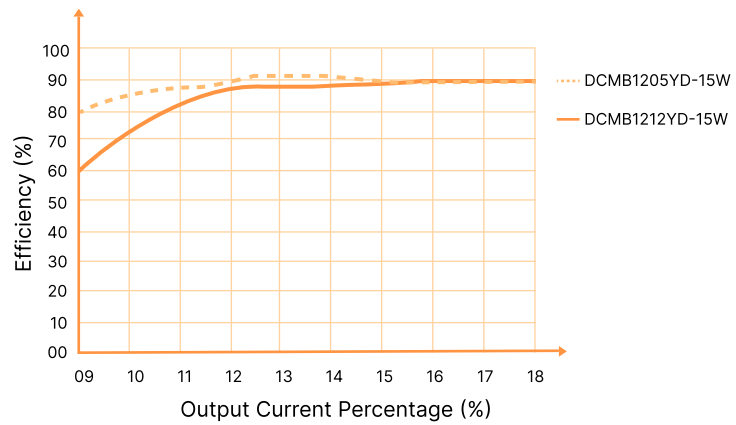
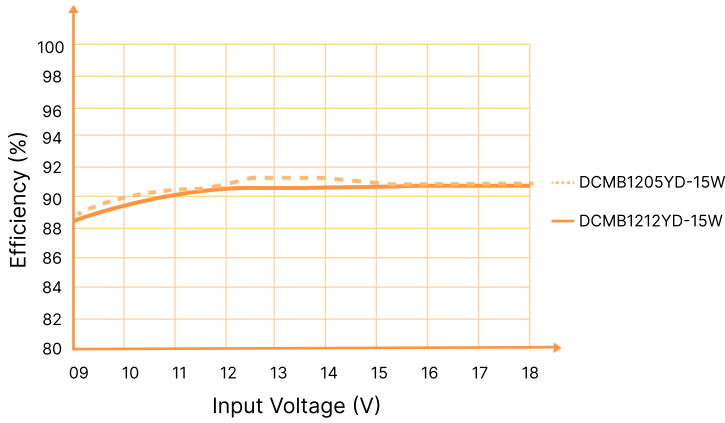
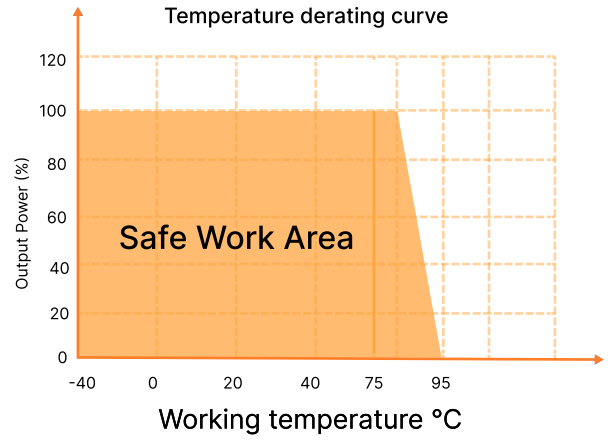
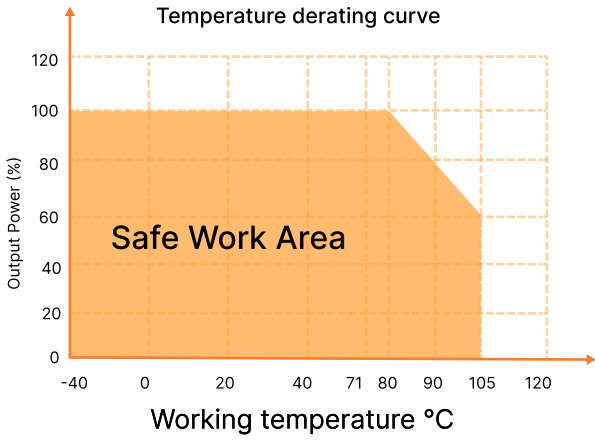

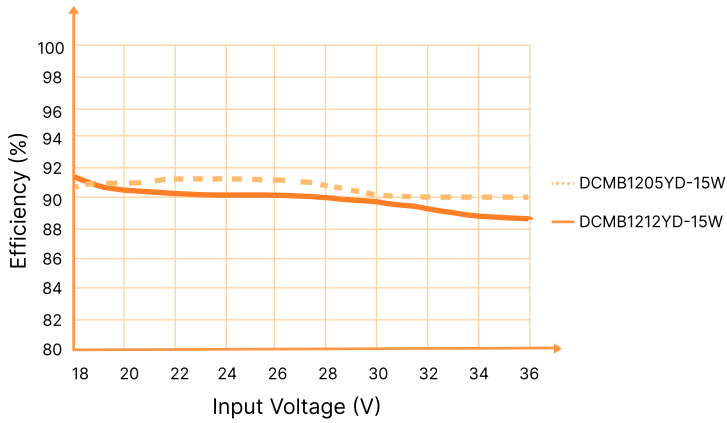

Efficiency Vs Input Voltage (Full Load)

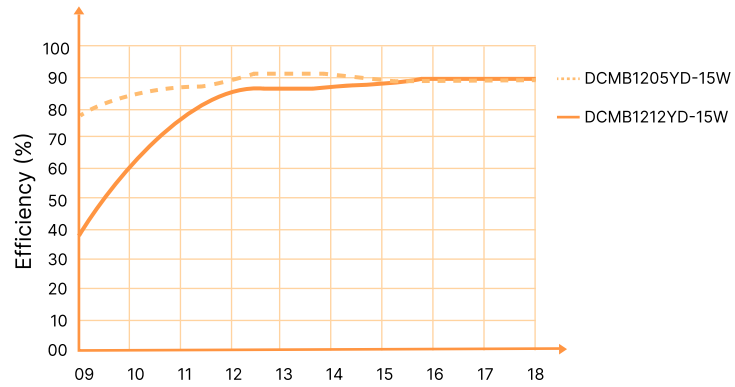

Efficiency Vs Input Voltage (Vin=12V)

### CIRCUIT DESIGN AND APPLICATION

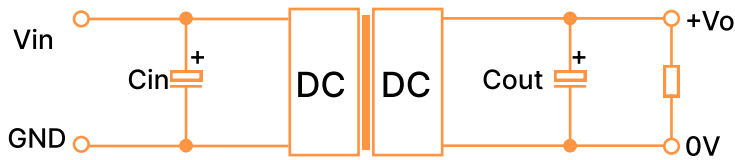
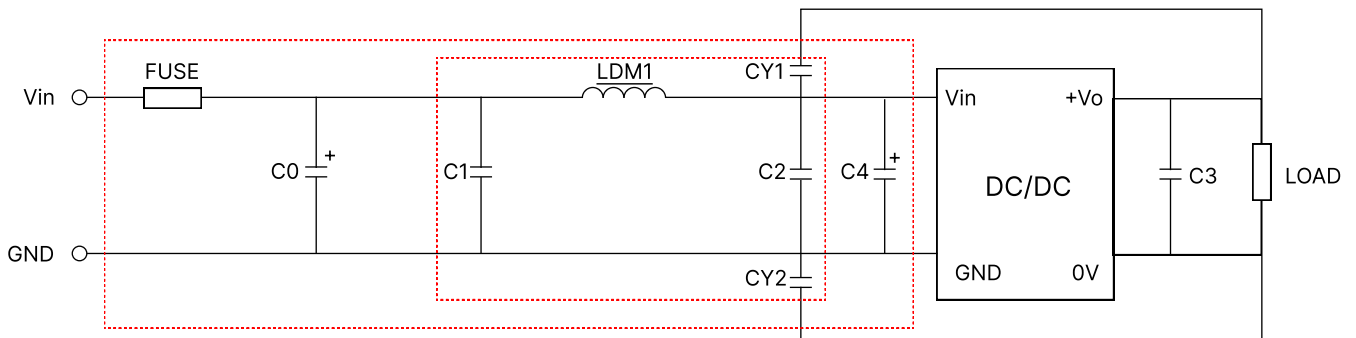
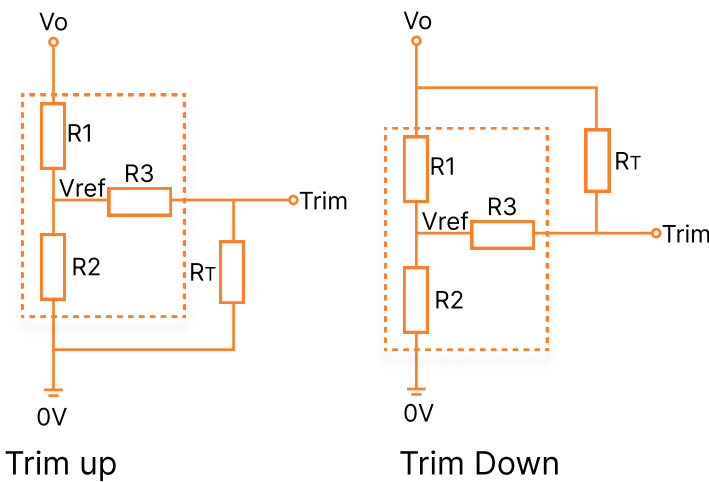

Fig 2

Vin (VDC)	Vout (VDC)	Cin	Cout
12	3.3/5	100µF/50V	100µF/16V
	12/15		100µF/25V
	24		47µF/50V
24	3.3/5	100µF/50V	100µF/16V
	12/15		100µF/25V
	24		47µF/50V
48	3.3/5	100µF/100V	100µF/16V
	12/15		100µF/25V
	24		47µF/50V



Vin (VDC)	Vin: 12VDC/24VDC	Vin: 48VDC
FUSE	Select fuse value according to actual input current	
C0, C4	330μF/50V	330μF/100V
C1, C2	4.7μF/50V	4.7μF/100V
C3	Refer to the Cout in Fig.2	
LDM1	2.2μH/4A	2.2μH/2A
CY1/CY2	1nF/2kV	



The Calculation formula for trim resistance

$$\begin{aligned} \text{Trim up: } R_T &= \frac{aR_2}{R_2-a} - R_3 & a &= \frac{V_{ref}}{V_o' - V_{ref}} R_1 \\ \text{Trim down: } R_T &= \frac{aR_1}{R_1-a} - R_3 & a &= \frac{V_o' - V_{ref}}{V_{ref}} R_2 \end{aligned}$$

$R_T$  is Trim resistance  
 $a$  = self-defined parameter;  
 $V_o'$  = desired output voltage

TRIM resistor connection (dashed line shows internal resistor network)

Vout(V)	R1(KΩ)	R2(KΩ)	R3(KΩ)	Vref(V)
3.3	4.772	2.87	15	1.25
5	2.883	2.87	10	2.5
12	11.000	2.87	17.4	2.5
15	14.494	2.87	17.4	2.5
24	24.872	2.87	20	2.5

OVERALL DIMENSIONS AND PIN FUNCTIONS

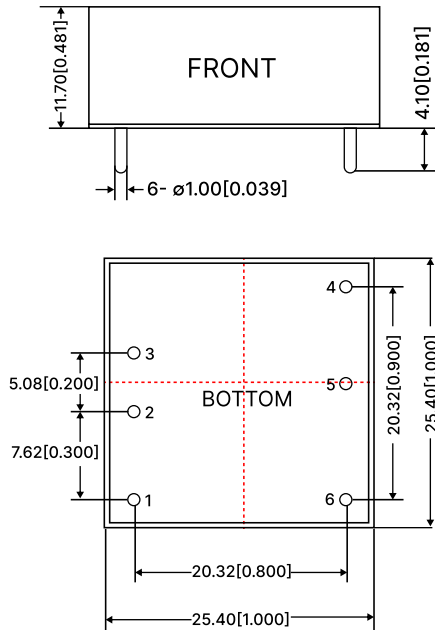
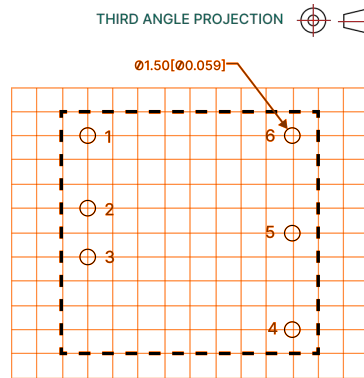

Figure 7: Overall dimensions



Note: Grid 2.54\*2.54

Unit: mm[inch]  
Pin diameter tolerances:  $\pm 0.10$   
General tolerances:  $\pm 0.50$

Table 3: Pin Function Table

Pin	Function
1	Ctrl
2	GND
3	Vin
4	+Vo
5	Trim
6	0V

PACKAGING METHOD

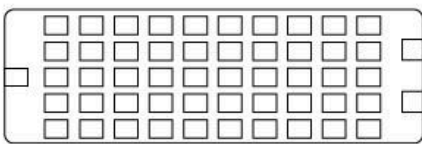

50 Pieces/Tube

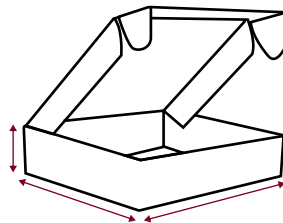

100 Pieces/Inner box

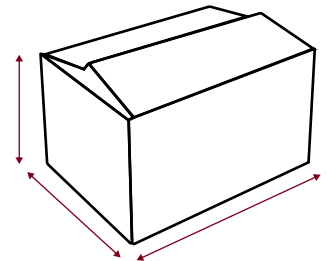

500 Pieces/Outer box

NOTES & INSTRUCTIONS

- 1.The input voltage shall not exceed the specified range value, otherwise permanent and unrecoverable damage maybe caused;
2. Unless otherwise specified,the parameters in this manual are measured at 25 °C,40%~75% humidity, input nominal voltage and output pure resistance mode under full load;
- 3.All index test methods are based on the company's enterprise standards.
- 4.The copyright and the final interpretation right of the product belong to RHENXV.