

ACS10W-xxV Series

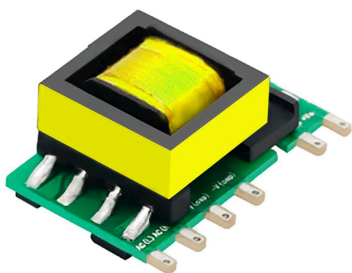

FEATURES

- Input voltage range: 85~305VAC (100~430VDC)
- Working temperature range: -40°C to +85°C
- Complete protection functions
- Industrial grade product technical design



DESCRIPTION

The ACS10W-xxV series is an efficient modular power supply for miniaturized bare boards, with advantages such as dual use of AC and DC, wide input voltage range, high reliability, low power consumption, and safe isolation. Widely applicable to industrial control, power instruments, smart homes, and other occasions that require strict volume requirements and low EMC requirements. If it is necessary to apply in harsh electromagnetic compatibility environments, EMC peripheral circuits must be added.

MODEL NUMBERING

ACS10W-xxV

Series Name Output Power Output Voltage

SELECTION GUIDE

Product Model	Output Voltage (Vo)	Output Current (Io)	Output Power (W)	Efficiency (230VAC, %/Typ.)	Maximum capacitive load (uF)
ACS10W-03V	3.3	2000	6.6	70	2200
ACS10W-05V	5	2000	10	76	1500
ACS10W-09V	9	1100	10	80	680
ACS10W-12V	12	830	10	81	470
ACS10W-15V	15	670	10	82	330
ACS10W-24V	24	420	10	83	100

INPUT CHARACTERISTICS

Parameter	Conditions	Min.	Typ.	Max.	Units
Input Voltage	AC Input	85	--	305	VAC
	DC Input	100	--	430	VDC
Input voltage frequency	AC Input	47	--	63	Hz
Input Current	115VAC	--	--	0.3	A
	230VAC	--	--	0.13	A
Inrush Current	115VAC	--	20	--	A
	230VAC	--	40	--	A
Input Fuse	External suggested (300V/1A)				

Remarks: This product does not support hot plug

OUTPUT CHARACTERISTICS

Parameter	Conditions	Min.	Typ.	Max.	Units
Output voltage accuracy	10% -100% load	--	--	+/-5	%
Linear regulation	Rated load	--	--	+/-1.5	%
Load regulation	10% to 100% load	--	--	+/-3	%
Minimum load		10	--	--	%
Standby power	At room temperature, 230VAC input	--	0.1	0.12	W
Ripple & Noise	20MHz bandwidth (peak to peak)	--	70	150	mV
Temperature drift coefficient	230VAC, 0 - 50°C, 100% load	--	+/-0.1	--	%/°C
Over Voltage Protection	3.3V / 5V	≤7.5V	Hiccup mode, self recovery, Or output voltage clamp		
	9V	≤15V			
	12V / 15V	≤20V			
	24V	≤30V			
Short circuit protection	Hiccup type, capable of long-term short circuit and self recovery				
Over Current protection	>110% I _o , Self recovering				
Over Temperature Protection	Hiccup mode, self recovery				

Note: The testing method for ripple and noise is parallel line testing, and a 100uF electrolytic capacitor and a 0.1uF ceramic capacitor need to be connected in parallel at the output end.

GENERAL CHARACTERISTIC

Parameter	Conditions		Min.	Typ.	Max.	Units
Isolation voltage	Input-Output	Test time 1 minute, Leakage current less than 5mA	3600	--	--	VAC
			5000			VDC
Insulation resistance	Input-Output	Environmental temperature: 25 ± 5 °C, Relative humidity: less than 95% RH, uncondensed, Test voltage: 500VDC.	100	--	--	MΩ
Working temperature			-40	--	+85	°C
Storage temperature			-40	--	+105	°C
Working humidity			20	--	85	%RH
Storage humidity			10	--	95	%RH
Switching frequency			--	65	--	KHz
Output power derating	Operating temperature derating	-20°C to -10°C	2.75	--	--	%/°C
		+50°C to +70°C	1.67	--	--	%%°C
	Input voltage derating	85VAC-100VAC	1.33	--	--	%/VAC
		277VAC-305VAC	0.71	--	--	%/VAC
	Altitude derating	2000m-5000m	0.67	--	--	%/Km
Leakage current	230VAC/50Hz	<0.1mA,RMS Max				
Mean Time Between Failures 【MTBF】	MIL-HDBK-217F@25°C	1000	--	--	kHours	
Safety Standards	Compliant with GB4943.1, BS EN/EN62368-1, EN60335-1, EN61558-1, IEC62368-1, EN62477-1; Security Class I.					

PHYSICAL CHARACTERISTICS

Parameter	Contents
Housing material	None (bare board)
Overall dimensions	32*20*15mm (L*W*H)
Weight	15g (Typ.)
Cooling mode	Natural air cooling

SAFETY & EMC

Parameter	Category	Content		
EMI	Conductive disturbance	CISPR32 EN55032	150kHz—30MHz, CLASS A	
		CISPR32 EN55032	150kHz—30MHz, CLASS B	
	Radiation disturbance	CISPR32 EN55032	30MHz—1GHz, CLASS A	
		CISPR32 EN55032	30MHz—1GHz, CLASS B*	
EMS	Electrostatic discharge	IEC/EN61000-4-2	Contact 1±6KV/Air ±8KV	Perf. Criteria A
	Radiated immunity	IEC/EN61000-4-3	80MHz - 1GHz 10V/m	Perf. Criteria A
	EFT	IEC/EN61000-4-4	±4KV, (5 or 100)kHz	Perf. Criteria A
	Surge immunity	IEC/EN61000-4-5	line to line ±2KV/line to PE ±4KV	Perf. Criteria A
		IEC/EN61000-4-5	line to line ±4KV/line to PE ±6KV	Perf. Criteria A
	Conducted disturbance immunity	IEC/EN61000-4-6	0.15MHz-80MHz 10Vr.m.s	Perf. Criteria A
	Voltage dip	IEC/EN61000-4-11	0%, 70%	Perf. Criteria A
Voltage Interruption	IEC/EN61000-4-11	0% of 230VAC, 0VAC, 5000ms	Perf. Criteria B	

CIRCUIT DESIGN REFERENCE

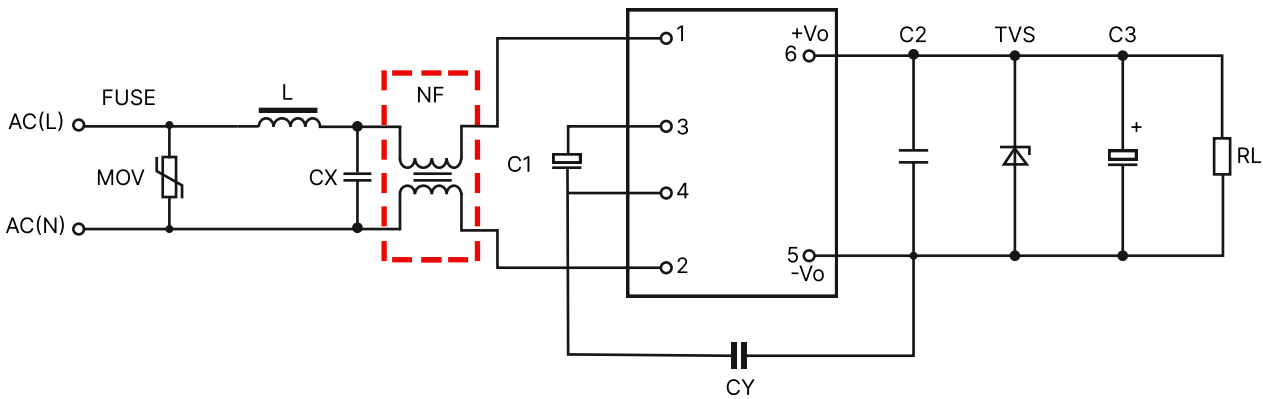

EMC Characteristics

Product Model	R	MOV	L (Must)	C1 (Must)	C2	CX	CY (Must)	C3	TVS
ACS10W-03V	Insurance resistor 10Ω/1W	10D561K	1mH	22μF/450V	104K/50V	104K/275VAC	1nF/400VAC	2200μF /16V	SMBJ7.0A
ACS10W-05V								1000μF /16V	SMBJ12A
ACS10W-09V								1000μF /25V	SMBJ20A
ACS10W-12V								680μF /35V	SMBJ30A
ACS10W-15V									
ACS10W-24V									

PRODUCT CHARACTERISTIC CURVE

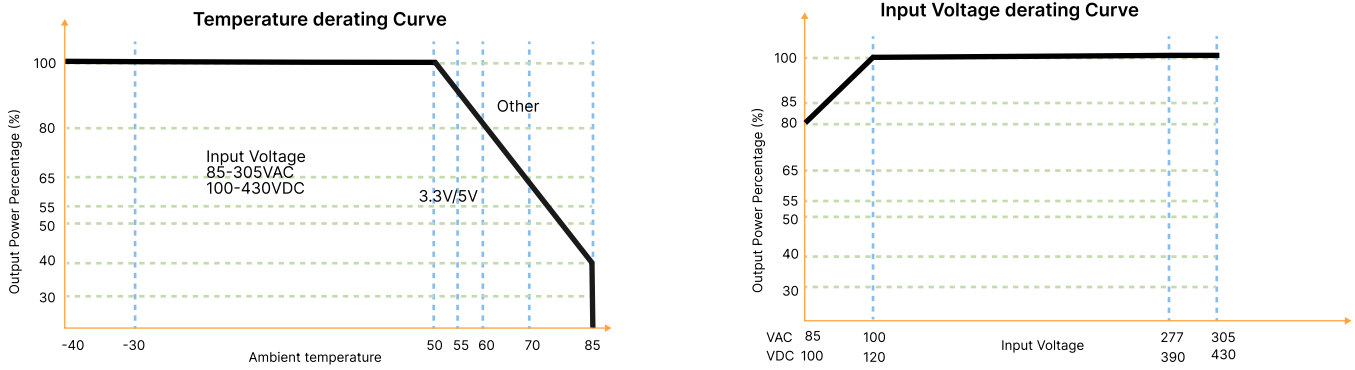

Figure 3: Voltage tolerance envelope

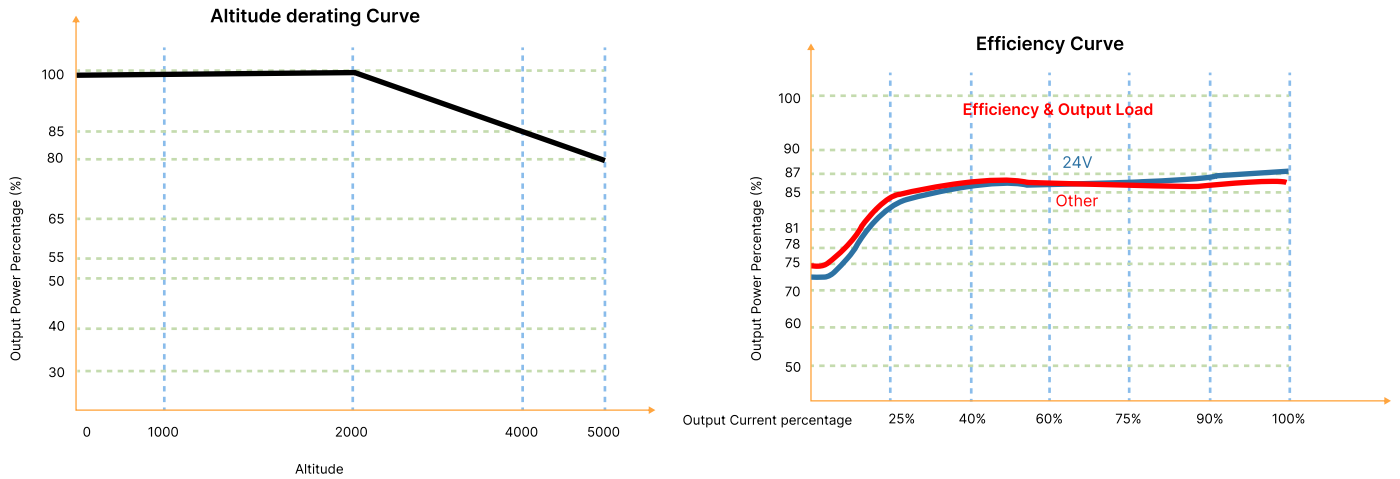

Figure 4: Temperature Derating Curve

Figure 5: Efficiency VS Output Load (Nominal Voltage Input)

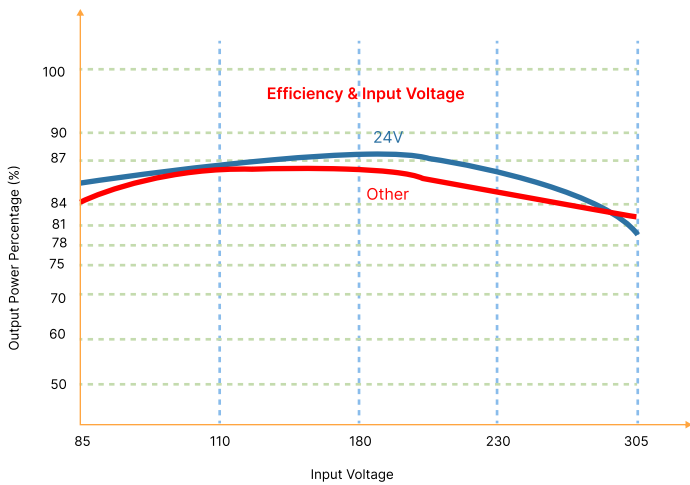

Figure 6: Efficiency VS Input Voltage (100% Load)

OVERALL DIMENSIONS AND PIN FUNCTIONS

Table 3: Pin Function Table

Pin	Function
1	AC(L)
2	AC(N)
3	+V(cap)
4	-V(cap)
5	-Vo
6	+Vo

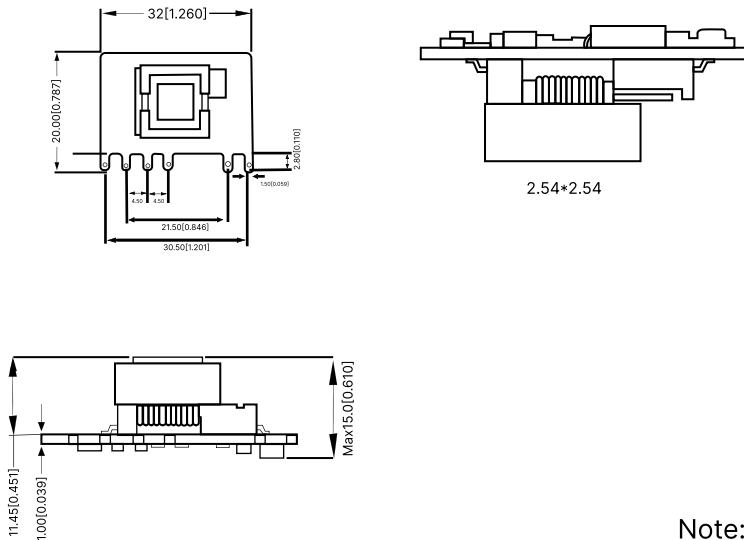

Figure 7: Overall dimensions

Note:

Dimensions in mm [inch]

Terminal diameter tolerance: ± 0.10 [± 0.004]Undeclared tolerance: ± 0.50 [± 0.020]

PACKAGING METHOD

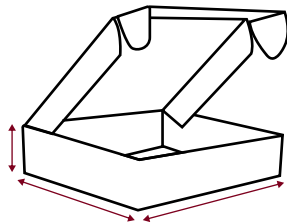

150 Pieces/Inner box

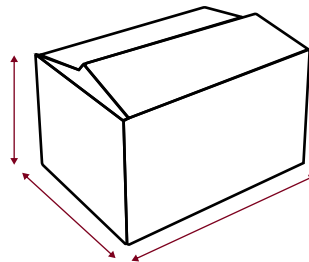

750 Pieces/Outer box

NOTES & INSTRUCTIONS

1. The input voltage shall not exceed the specified range value, otherwise permanent and unrecoverable damage maybe caused;
2. Unless otherwise specified, the parameters in this manual are measured at 25°C, 40%~75% humidity, input nominal voltage and output pure resistance mode under full load;
3. All index test methods are based on the company's enterprise standards.
4. The copyright and the final interpretation right of the product belong to RHENXV.