

ACE20W-xxVM



CE Report

RoHS



FEATURES

- Input voltage range: 85~305VAC (100~430VDC)
- Working temperature range: -40°C to +85°C
- Complete protection functions
- Industrial grade product technical design
- High efficiency and reliability
- 3 Years warranty

DESCRIPTION

The ACE20W-xxVM series is a power system suitable for wireless networks, telecommunications/data communication, power systems, industrial control systems, measuring instruments, and intelligent fields. Suitable for designs that require large input range fluctuations, power isolation, small board space, and modular product functionality to improve product reliability

MODEL ENCODING

ACE20W-xxVM



SELECTION GUIDE

Product Model	DC Voltage (Vdc)	Rated Current (mA)	Output Power (W)	Efficiency (230VAC, %/Typ.)
ACE20W-03VM	3.3	4500	14.85	80
ACE20W-05VM	5	4000	20	82
ACE20W-09VM	9	2200	20	84
ACE20W-12VM	12	1700	20	85
ACE20W-15VM	15	1300	20	85
ACE20W-24VM	24	800	20	86

INPUT CHARACTERISTIC

Parameter	Conditions	Min.	Typ.	Max.	Units
Input Voltage	AC Input	85	--	305	VAC
	DC Input	100	--	430	VDC
Input voltage frequency	AC Input	47	--	63	Hz
Input Current	115VAC	--	--	0.125	A
	230VAC	--	--	0.08	A
Input fuse	Built in fuse, 300V	--	2	--	A

Remarks: This product does not support hot plug

OUTPUT CHARACTERISTIC

Parameter	Conditions	Min.	Typ.	Max.	Units
Output voltage accuracy	10% -100% load	--	±2	--	%
Linear regulation rate	Rated load	--	±0.5	--	%
Load regulation rate	10% to 100% load	--	±1	--	%
Ripple & Noise	20MHz bandwidth (peak to peak)	---	100	--	mV
Temperature drift coefficient	230VAC, 0 - 50°C,100% load	---	±0.02	--	%/°C
Short circuit protection	Hiccup type, can self recover after removing abnormal load conditions, and can self recover after troubleshooting				
Overcurrent protection	110% -300% I _o , Self recovering				
Over Temperature Protection	Hiccup mode, self recovery				

Note: The testing method for ripple and noise is parallel line testing, and a 100uF electrolytic capacitor and a 0.1uF ceramic capacitor need to be connected in parallel at the output end

GENERAL CHARACTERISTIC

Parameter	Conditions		Min.	Typ.	Max.	Units
Isolation voltage	Input-Output	Test time 1 minute, Leakage current less than 5mA	4200	--	--	VAC
Insulation resistance	Environmental temperature: 25 ± 5 °C, Relative humidity: less than 70% RH, uncondensed, Test voltage: 500VDC.		100	--	--	MΩ
Working temperature			-40	--	+85	°C
Storage temperature			-40	--	+85	°C
Working humidity			20	--	85	%RH
Storage humidity			10	--	95	%RH
Output power derating	Operating temperature derating	-20°C to -10°C	4.0	--	--	%/°C
		+50°C to +70°C	2.5	--	--	%/°C
	Input voltage derating	85VAC-100VAC	1.33	--	--	%/VAC
		277VAC-305VAC	1.25	--	--	%/VAC
	Altitude derating	2000m-5000m	0.67	--	--	%/Km
Leakage current	265VAC/50Hz		<0.11mA,RMS Max			
Mean Time Between Failures 【MTBF】	MIL-HDBK-217F@25°C		200	--	--	kHours
Safety standards	Compliant with EN62368-1, UL62368					

Note: The testing method for ripple and noise is parallel line testing, and a 100uF electrolytic capacitor and a 0.1uF ceramic capacitor need to be connected in parallel at the output end

PHYSICAL CHARACTERISTICS

Parameter	Contents
Housing material	(UL94V-0)
Overall dimensions	52.40 × 27.20 × 24.00 mm (L*W*H)
Weight	55g (Typ.)
Cooling mode	Natural air cooling

EMC CHARACTERISTICS

Parameter	Category	Content
EMI	Conductive disturbance	EN55022 CLASS B
	Radiation disturbance	EN55022 CLASS B
EMC	Electrostatic discharge	IEC/EN61000-4-2 Contact ±6kV/Air ±8kV
	Radiated immunity	IEC/EN61000-4-3
	Pulse group immunity	IEC/EN61000-4-4 level 3 2 kV
	Surge immunity	IEC/EN61000-4-5 level 3 1kV/2kV

CIRCUIT DESIGN AND APPLICATION

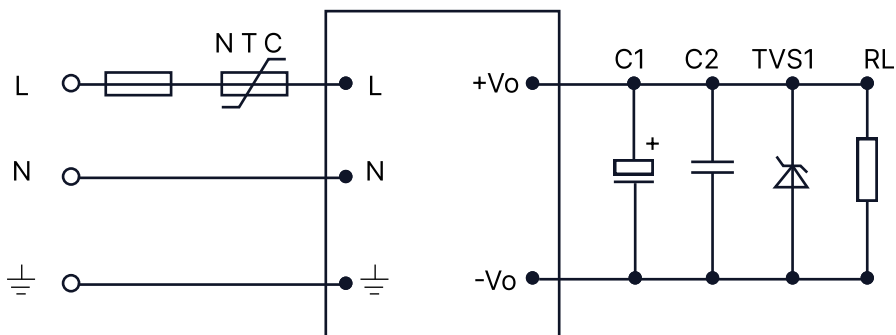

Typical application circuit

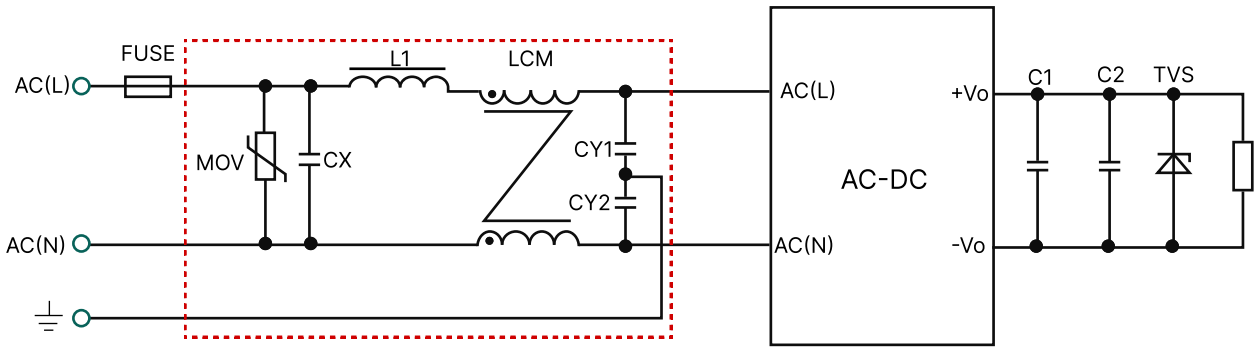

Typical values of application circuit parameters

Category	Content
MOV	14D471
CY1、CY2	1000pF/400VAC
CX	0.1uF/275VAC
LCM	>10mH
L1	4.7uH/2A
FUSE	2A/300V

PRODUCT CHARACTERISTIC CURVE

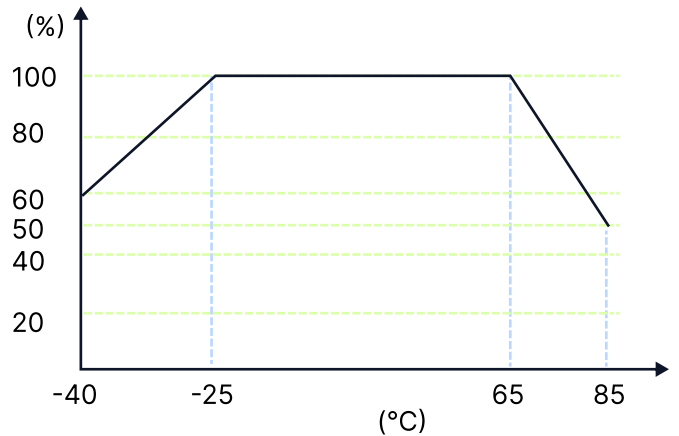
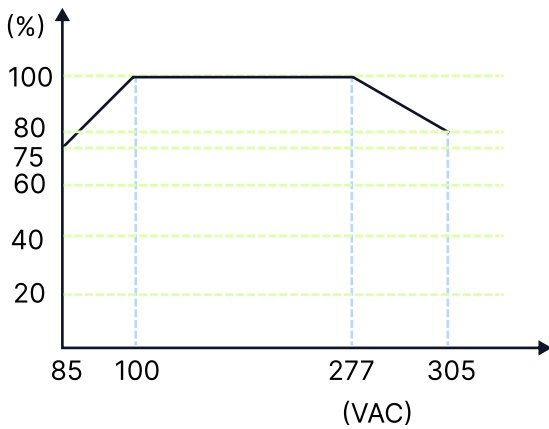

OVERALL DIMENSIONS AND PIN FUNCTIONS

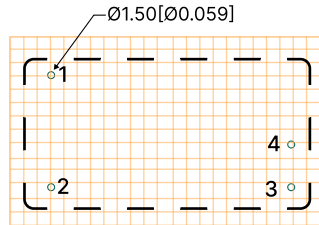
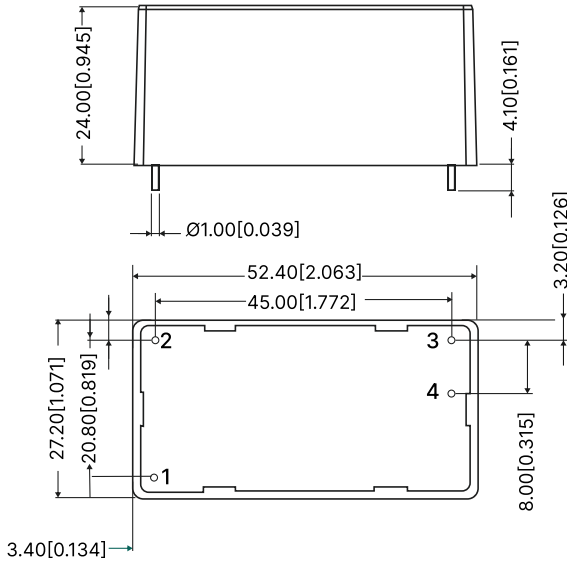

Note: The grid distance is 2.54mm*2.54mm

Note:
 Dimensions in mm
 Terminal diameter tolerance: +/-0.10
 Undeclared tolerance: +/-0.50

Table 3: Pin Function Table

Pin	Function
1	AC(L)
2	AC(N)
3	-VO
4	+VO

Figure 7: Overall dimensions

NOTES & INSTRUCTIONS

1. The input voltage shall not exceed the specified range value, otherwise permanent and unrecoverable damage may be caused;
2. Unless otherwise specified, the parameters in this manual are measured at 25 °C, 40%~75% humidity, input nominal voltage and output pure resistance mode under full load;
3. All index test methods are based on the company's enterprise standards.
4. The copyright and the final interpretation right of the product belong to HENXV.