

DCWB_YD-10W Series



CE Report

RoHS



FEATURES

- Wide voltage range input (4:1)
- Wide operating temperature range : -40°C to +85°C
- Up to 88% efficiency
- Standby power consumption: 0.12W
- Output short circuit, overcurrent, overload protection
- 3 Years Warranty

DESCRIPTION

DC-DC module power supply, Wide voltage input, Power 10W, Isolated, Regulated, Single output, DIP packaging.

MODEL NUMBERING

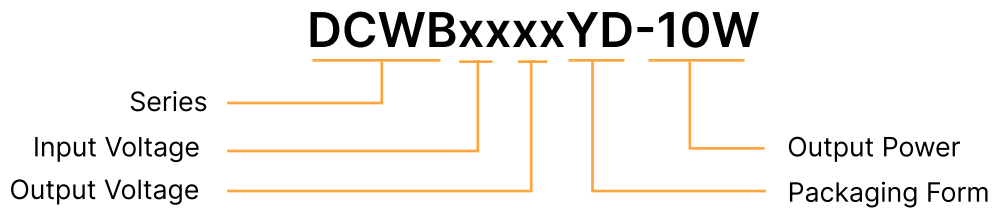

SELECTION GUIDE

Product Model	Input Voltage Standard Value(range)	Output Voltage (Vdc)	Output Current (mA) (Max./Min.)	Efficiency % (Min./Typ.)	Maximum capacitive load (μ F)
DCWB2403YD-10W	24VDC (9-36)	3.3	2400/0	75/77	2200
DCWB2405YD-10W		5	2000/0	80/82	2200
DCWB2409YD-10W		9	1111/0	83/85	680
DCWB2412YD-10W		12	833/0	84/86	470
DCWB2415YD-10W		15	667/0	84/86	330
DCWB2424YD-10W		24	416/0	86/88	100

Product Model	Input Voltage Standard Value(range)	Output Voltage (Vdc)	Output Current (mA) (Max./Min.)	Efficiency % (Min./Typ.)	Maximum capacitive load (μ F)
DCWB4803YD-10W	48VDC (18-75)	3.3	2400/0	77/79	2200
DCWB4805YD-10W		5	2000/0	81/83	2200
DCWB4809YD-10W		9	1111/0	85/88	680
DCWB4812YD-10W		12	833/0	85/87	470
DCWB4815YD-10W		15	667/0	85/87	330
DCWB4824YD-10W		24	416/0	86/88	100

INPUT CHARACTERISTICS

Parameter	Conditions	Min.	Typ.	Max.	Units	
Input Current (full load /no load)	24VDC nominal input series nominal input voltage	3.3V Output	--	429/5	440/12	mA
		Others	--	502/5	521/12	mA
	48VDC nominal input series nominal input voltage	3.3V Output	--	190/4	215/8	mA
		Others	--	215/4	258/8	mA
Reflected Ripple Current	Nominal voltage input@24VDC	--	40	--	mA	
	Nominal voltage input@48VDC	--	30	--	mA	
Input Impulse Voltage	Nominal voltage input@24VDC	-0.7	--	50	VDC	
	Nominal voltage input@48VDC	-0.7	--	100	VDC	
Starting Voltage	Nominal voltage input@24VDC	--	--	9	VDC	
	Nominal voltage input@48VDC	--	--	18	VDC	
Under Voltage Protect	Nominal voltage input@24VDC	5.5	6.5	--	VDC	
	Nominal voltage input@48VDC	12	15.5	--	VDC	
Start Time	Nominal Input Voltage & Constant Resistance Load	--	10	--	VDC	
Remote control foot (Some models are applicable)		Ctrl hovering or connected to TTL high level (3.5-12VDC)				
	Module shutdown	Ctrl connected to GND or low level (0-1.2VDC)				
	Input current during shutdown	--	06	10	mA	
Input filter	PI type					

Remarks: This product does not support hot plug

OUTPUT CHARACTERISTIC

Parameter	Conditions	Min.	Typ.	Max.	Units
Output voltage accuracy	0% -100% Load	--	±1	±3	%
Linear regulation rate	Input voltage variation+/- 1%	--	±0.2	±0.5	%
Load regulation rate	10% to 100% load	--	±0.5	±1	%
Ripple & Noise	20MHz bandwidth	--	40	80	mVp-p
Dynamic response step deviation		--	±3	±5	%
Dynamic response recovery time		--	300	500	μs
Temperature drift coefficient	100% load	--	--	±0.03	%/°C
Output overvoltage protection	Full voltage range input	110	--	160	%Vo
Output overcurrent protection	Full voltage range input	110	140	190	%Io
Short circuit protection	Sustainable, Self-healing				

Note: The testing method for ripple and noise is the parallel line testing method.

GENERAL CHARACTERISTIC

Parameter	Conditions	Min.	Typ.	Max.	Units
Isolation voltage	Input-output, test time 1 minute, Leakage current less than 1 mA	1500	--	--	VDC
Insulation resistance	Input-output, Insulation voltage 500VDC	1000	--	--	MΩ
Isolation capacitance	Input-output, 100KHz/0.1V	--	1000	--	pF
Working temperature	Temperature ≥ 71 °C for derating (See Figure 4)	-40	--	+85	°C
Storage temperature		-55	--	+125	°C
Storage humidity	Non condensing	5	--	95	%RH

Parameter	Conditions	Min.	Typ.	Max.	Units
Housing temperature rise during operation	Ta=25°C,Nominal input, Full output	--	15	25	°C
Soldering temperature resistance of pins	The distance from the welding spot to the shell is 1.5mm, 10 seconds	--	--	300	°C
	REFLOW: Peak temperature Tc≤245°C, maximum time above 217°C for 60 seconds.	--	--	245	°C
Switching frequency	Full load, Nominal in put voltage	--	350	--	kHz
Mean time between faliures 【MTBF】	MIL-HDBK-217F@25°C	1000	--	--	kHours

PHYSICAL CHARACTERISTICS

Parameter	Contents
Housing material	Aluminum alloy
Overall dimensions	25.40 × 25.40 × 11.70 mm
Weight	15g(Typ.)
Cooling mode	Natural air cooling

EMC CHARACTERISTICS

Parameter	Category	Content
EMI	Conductive disturbance	CISPR32/EN55032 CLASS B (The recommended circuit is shown in Figure 2)
	Radiation disturbance	CISPR32/EN55032 CLASS B (The recommended circuit is shown in Figure 2)
EMS	Electrostatic discharge	IEC/EN61000-4-2 Contact ±4KV perf. Criteria B

CIRCUIT DESIGN AND APPLICATION

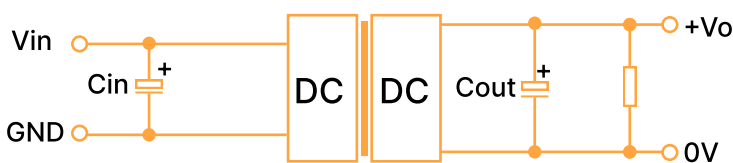

Figure 1: Application circuit

Table 1:
Recommended Capacitive Load Values

Vin(VDC)	Cin(μF)	Vo(VDC)	Cout(μF)
Nominal voltage	100	Nominal voltage	10

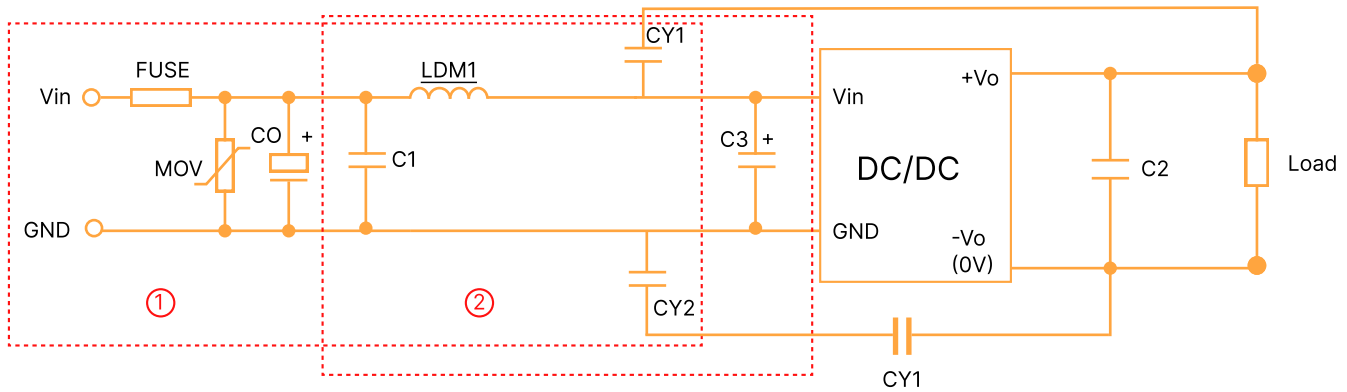

Figure 2: EMC Typical Recommended Circuits

Table 2:
Recommended Circuit Parameter Values

Model	Vin:12V	Vin:24V
FUSE	Choose according to actual input current	
MOV	330μF/50V	330μF/100V
C0, C3	1μF/50V	1μF/50V
C1	4.7μH/3.1A	4.7μH/3.1A
C2	Refer To The Cout In Fig.2	
LDM1	4.7μH	
CY1, CY2	1nF/2kV	

1. Typical application: If further reduction of input and output ripple is required, a capacitor Filter network can be connected at the input and output ends. The application circuit is shown in Figure 1. However, suitable Filter capacitors should be selected. If the capacitance is too large, it may cause overcurrent or poor startup of the power supply. For each output, while ensuring safe and reliable operation, the recommended capacitance load values are shown in Table 1.
2. EMC requirements: For situations with high EMC requirements, a typical EMC recommended circuit is shown in Figure 2.
3. Input requirements: Ensure that the Fluctuation range of the input voltage does not exceed the upper and lower limits of the input voltage Specified in this data sheet, and the input power must be greater than the output power Specified in this data sheet. For situations with a 24V input voltage, it is recommended to connect a TVS tube between the positive and negative input pins for protection (recommended parameters for TVS tubes: 30V, bidirectional, SOD-123 packaging).
4. Output load requirements: Try to avoid using it without load as much as possible; When the actual power of the load is less than 10% of the rated output power in this data sheet, or when it needs to be used in no-load situations, it is recommended to connect a load resistor externally at the output end. The load resistor can be calculated according to 5-10% of the rated power in this data sheet. The calculation formula for the load resistor value is $R_L = V_{out}^2 / (P_{out} * 10\%)$.
5. Overload protection: Under normal working conditions, the output circuit of this product has no protection function for overload situations. The simplest method is to connect a self recovery fuse in series at the input end, or add a circuit breaker outside the circuit; Or during design and selection, the actual power of the circuit should be around 60-80% of the rated power in this data sheet.

PRODUCT CHARACTERISTIC CURVE

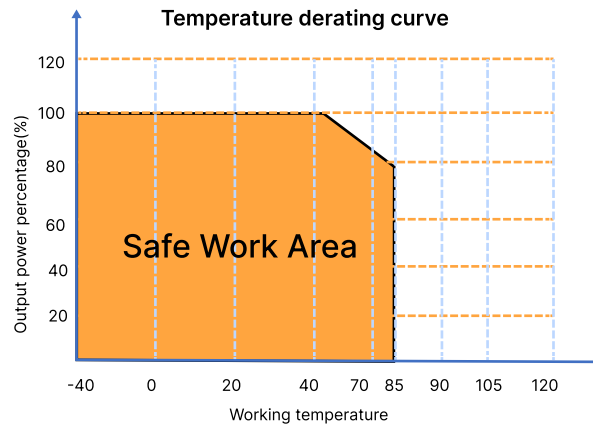

Figure 4: Temperature Derating Curve

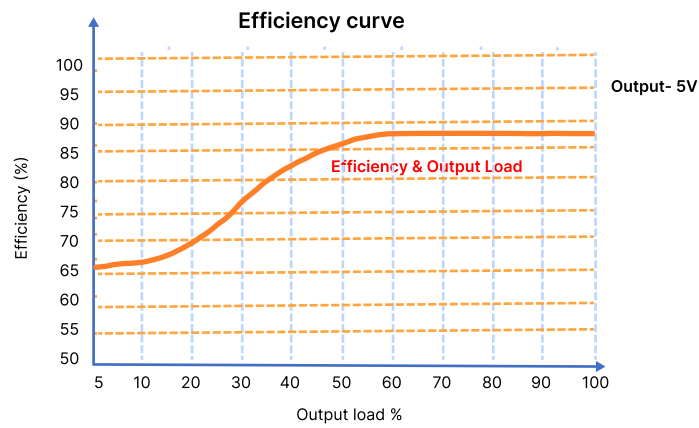

Figure 5: Efficiency Vs Output Load (Nominal Voltage Input)

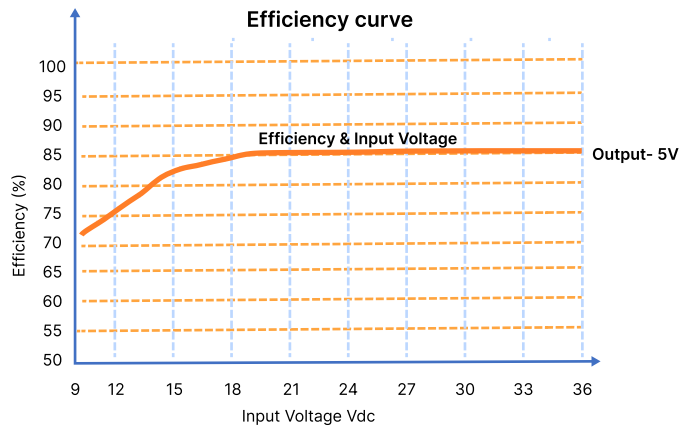

Figure 5: Efficiency Vs Input Voltage (100% Load)

OVERALL DIMENSIONS AND PIN FUNCTIONS

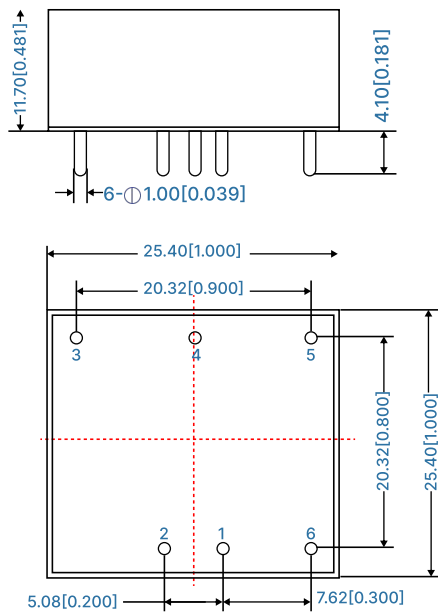

Figure 7: Overall dimensions

Note:
Dimensions in mm
Terminal diameter tolerance: +/-0.10
Undeclared tolerance: +/-0.50

Table 3: Pin Function Table

Pin	Function
1	GND
2	Vin
3	+Vo
4	No Pin
5	0V
6	Ctrl

PACKAGING METHOD

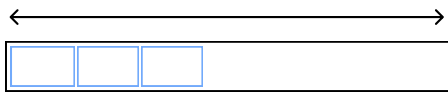

50 Pieces/Tube

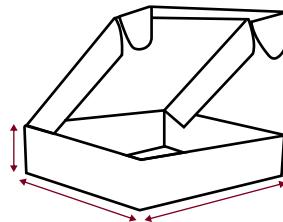

100 Pieces/Inner box

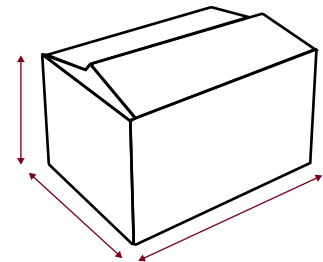

500 Pieces/Outer box

NOTES & INSTRUCTIONS

- 1.The input voltage shall not exceed the specified range value, otherwise permanent and unrecoverable damage maybe caused;
2. Unless otherwise specified,the parameters in this manual are measured at 25 °C,40%~75% humidity, input nominal voltage and output pure resistance mode under full load;
- 3.All index test methods are based on the company's enterprise standards.
- 4.The copyright and the final interpretation right of the product belong to HENXV.