

## DCWB\_S-6W Series

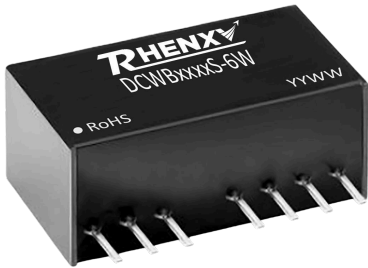

### FEATURES

- Wide voltage range input (4:1)
- Working temperature range: -40°C to +105°C
- Up to 85% efficiency
- Standby power consumption: 0.3W
- Output short circuit, overcurrent, overload protection
- 3 Years Warranty

### APPLICATIONS

- Industrial Control
- Instrumentation
- Electric Power
- Communication
- Medical

### DESCRIPTION

DC-DC module power supply, Wide voltage input, Power 6W, Isolated, Regulated, Single output, SIP packaging.

### MODEL NUMBERING

## DCWBxxxxS-6W



### SELECTION GUIDE

Product Model	Input Voltage Standard Value(range)	Output Voltage (Vdc)	Output Current (mA) (Max./Min.)	Efficiency % (Min./Typ.)	Maximum capacitive load ( $\mu$ F)
DCWB2403S-6W	24VDC (9-36)	3.3	1350/0	76/78	1800
DCWB2405S-6W		5	1200/0	80/82	1000
DCWB2409S-6W		9	667/0	82/84	470
DCWB2412S-6W		12	500/0	83/85	470
DCWB2415S-6W		15	400/0	83/85	220
DCWB2424S-6W		24	250/0	83/85	100

Product Model	Input Voltage Standard Value(range)	Output Voltage (Vdc)	Output Current (mA) (Max./Min.)	Efficiency % (Min./Typ.)	Maximum capacitive load ( $\mu$ F)
DCWB4803S-6W	48VDC (18-75)	3.3	1600/0	76/79	1200
DCWB4805S-6W		5	1200/0	80/83	680
DCWB4809S-6W		9	667/0	82/84	330
DCWB4812S-6W		12	500/0	84/86	330
DCWB4815S-6W		15	400/0	85/87	150
DCWB4824S-6W		24	250/0	85/87	68

### Input Characteristics

Parameter	Conditions	Min.	Typ.	Max.	Units	
Input Current (full load /no load)	24VDC nominal input series nominal input voltage	3.3V Output	--	238/5	245/12	mA
		5V Output	--	305/5	313/12	mA
		Others	--	298/10	305/16	
	48VDC nominal input series nominal input voltage	3.3V, 5V Output	--	158/5	165/12	mA
		Others	--	143/10	156/16	
Reflected ripple current		--	50	--	mA	
Input impulse voltage (1sec. max.)	Nominal voltage input@24VDC	-0.7	--	50	VDC	
	Nominal voltage input@48VDC	-0.7	--	100	VDC	
Starting voltage	Nominal voltage input@24VDC	--	--	09	VDC	
	Nominal voltage input@48VDC	--	--	18	VDC	

**INPUT CHARACTERISTICS**

Parameter	Conditions	Min.	Typ.	Max.	Units
Under voltage protect	Nominal voltage input@24VDC	5.5	6.5	--	VDC
	Nominal voltage input@48VDC	13	14.5	--	VDC
Start Time		--	10	--	ms
Remote control foot (Some models are applicable)	Module On	Ctrl hovering or connected to TTL high level (3.5 12VDC)			
	Module shutdown	Ctrl connected to GND or low level (0 1.2VDC)			
	Input current during shutdown	--	06	10	mA
Input filter	PI type				

Remarks: This product does not support hot plug

**OUTPUT CHARACTERISTICS**

Parameter	Conditions	Min.	Typ.	Max.	Units
Output voltage accuracy	0% -100% Load	--	±1	±3	%
Linear regulation rate	Input voltage variation+/- 1%	--	--	±1.5	%
Load regulation rate	Input voltage variation+/- 1%	--	±0.5	±1.5	%
Ripple & Noise	20MHz bandwidth	--	30	100	mVp p
Dynamic response step deviation		--	±3	±5	%
Dynamic response recovery time		--	300	500	µs
Temperature drift coefficient	100% load	--	±0.03	--	%/°C
Output over voltage protection	Full voltage range input	110	--	160	%Vo
Output over current protection	Full voltage range input	110	140	190	%Io
Short circuit protection	Sustainable, Self healing				

Note: The Testing Method For Ripple And Noise Is The Parallel Line Testing Method.

## GENERAL CHARACTERISTIC

Parameter	Conditions	Min.	Typ.	Max.	Units
Isolation voltage	Input output, test time 1 minute, Leakage current less than 1 mA	1500	--	--	VDC
Insulation resistance	Input output, Insulation voltage 500VDC	1000	--	--	MΩ
Isolation capacitance	Input output, 100KHz/0.1V	--	120	1000	pF
Working temperature	Temperature $\geq 71$ °C for derating (See Figure 4)	-40	--	+105	°C
Storage temperature		-55	--	+125	°C
Storage humidity	Non condensing	--	--	95	%RH
Housing temperature rise during operation	Ta=25°C, Nominal input, Full output	--	15	25	°C
Soldering temperature resistance of pins	The distance from the welding spot to the shell is 1.5mm, 10 seconds	--	--	300	°C
	REFLOW: Peak temperature Tc $\leq 245$ °C, maximum time above 217°C for 60 seconds.	--	--	245	°C
Switching frequency	Full load, Nominal input voltage	--	270	--	kHz
Mean time between failures 【MTBF】	MIL HDBK-217F@25°C	1000	--	--	kHours

## PHYSICAL CHARACTERISTICS

Parameter	Conditions
Housing material	Black flame retardant and heat resistant plastic (UL94V 0)
Overall dimensions	22.00 × 9.50 × 12.00 mm
Weight	4.7g(Typ.)
Cooling mode	Natural air cooling

**EMC CHARACTERISTICS**

Parameter	Category	Content
EMI	Conductive disturbance	CISPR32/EN55032 CLASS B (The recommended circuit is shown in Figure 2)
	Radiation disturbance	CISPR32/EN55032 CLASS B (The recommended circuit is shown in Figure 2)
EMS	Electrostatic discharge	IEC/EN61000-4-2 Contact ±4KV perf. Criteria B

**CIRCUIT DESIGN AND APPLICATION**

**1. Ripple & Noise**

The general performance of all DC/DC converters of this series is tested in accordance with the test circuit recommended in Figure 2, Figure 3 is used for ripple noise test.

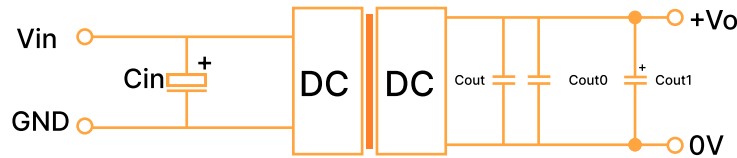

Figure 2

Parameter	Cin	Vo(VDC)	Cout	Cout 0	Cout 1
Vin:24VDC	100µF/100V	3.3/5/9	22µF/16V	1µF/50V	10µF/50V Tantalum Capacitors
		12/15	22µF/25V	1µF/50V	10µF/50V Tantalum Capacitors
		24	22µF/50V	1µF/50V	10µF/50V Tantalum Capacitors
Vin:48VDC	100µF/100V	3.3/5	22µF/16V	1µF/50V	10µF/50V Tantalum Capacitors
		9/12/15/24	10µF/50V	1µF/50V	10µF/50V Tantalum Capacitors

**2. Typical application**

Input and/or output ripple can be further reduced by appropriately increasing the input & output capacitor values Cin and Cout and/or by selecting capacitors with a low ESR (equivalent series resistance). Also make sure that the capacitance is not exceeding the specified max. capacitive load value of the product.

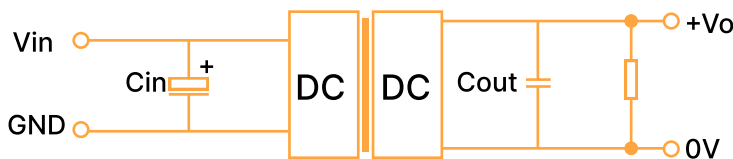

Figure 3: Typical Application circuit

Parameter	Cin	Vo(VDC)	Cout
Vin:24VDC	100µF/100V	3.3/5/9	22µF/16V
		12/15	22µF/25V
		24	22µF/50V
Vin:48VDC	100µF/100V	3.3/5	22µF/16V
		9/12/15/24	10µF/50V

### 3. EMC compliance circuit

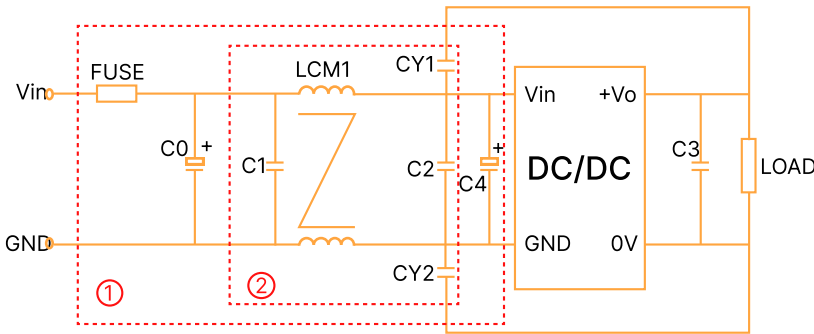

Figure 4: EMC compliance circuit

① in Fig. 4 for Immunity test and part ② for Emissions test. Select based on needs.

Parameter	VIn: 24VDC
FUSE	Choose according to actual input current
C0/C4	330μF/50V
C1/C2	10μF/50V
C3	22μF/50V
LCM1	470μH
CY1/CY2	1nF/400VAC

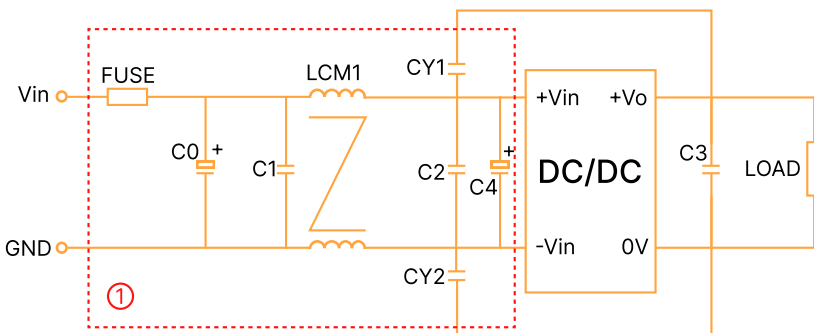

Figure 5: EMC compliance circuit

EMC and EMI tests Part ① in Fig. 5.

Parameter	VIn: 48VDC
FUSE	Choose according to actual input current
C0	200μF/100V
C1/C2	10μF/100V
C3	22μF/100V
LCM1	470μH
C4	330μF/100V
CY1/CY2	1nF/400VAC

1. Typical application: If further reduction of input and output ripple is required, a capacitor Filter network can be connected at the input and output ends. The application circuit is shown in Figure 1. However, suitable Filter capacitors should be selected. If the capacitance is too large, it may cause overcurrent or poor startup of the power supply. For each output, while ensuring safe and reliable operation, the recommended capacitance load values are shown in Table 1.

2. EMC requirements: For situations with high EMC requirements, a typical EMC recommended circuit is shown in Figure 2.

3. Input requirements: Ensure that the Fluctuation range of the input voltage does not exceed the upper and lower limits of the input voltage Specified in this data sheet, and the input power must be greater than the output power Specified in this data sheet. For situations with a 24V input voltage, it is recommended to connect a TVS tube between the positive and negative input pins for protection (recommended parameters for TVS tubes: 30V, bidirectional, SOD-123 packaging).

4. Output load requirements: Try to avoid using it without load as much as possible; When the actual power of the load is less than 10% of the rated output power in this data sheet, or when it needs to be used in no-load situations, it is recommended to connect a load resistor externally at the output end. The load resistor can be calculated according to 5-10% of the rated power in this data sheet. The calculation formula for the load resistor value is  $R_L = V_{out}^2 / (P_{out} * 10\%)$ .

5. Overload protection: Under normal working conditions, the output circuit of this product has no protection function for overload situations. The simplest method is to connect a self recovery fuse in series at the input end, or add a circuit breaker outside the circuit; Or during design and selection, the actual power of the circuit should be around 60-80% of the rated power in this data sheet.

PRODUCT CHARACTERISTIC CURVE

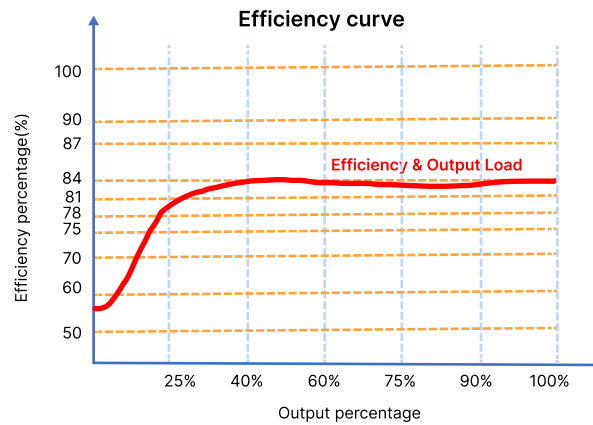
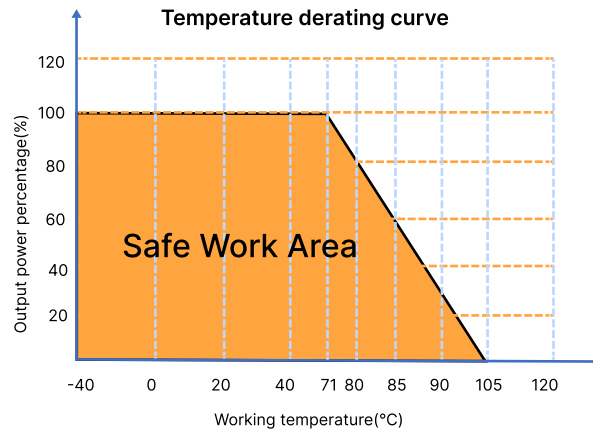

Figure 5: Efficiency Vs Output Load (Nominal Voltage Input)

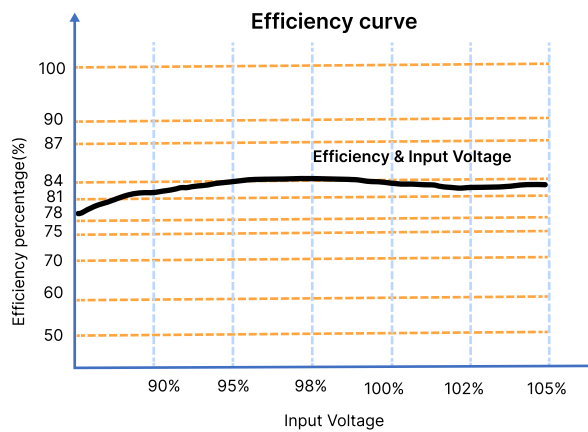

Figure 6: Efficiency Vs Input Voltage (100% Load)

OVERALL DIMENSIONS AND PIN FUNCTIONS

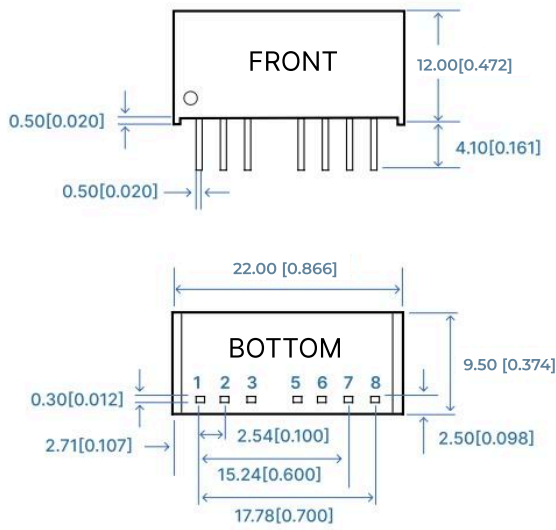
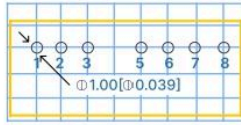

Figure 7: Overall dimensions

Note: The grid distance is 2.54mm \* 2.54mm



Note:  
Dimensions in mm  
Terminal diameter tolerance: +/-0.10  
Undeclared tolerance: +/-0.50

Table 3: Pin Function Table

Pin	Function
1	GND
2	Vin
3	Ctrl
5	NC
6	+Vo
7	0V
8	NC

\*NC cannot be connected to any external circuits

PACKAGING METHOD

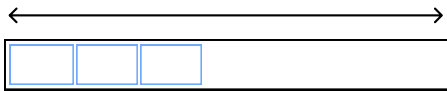

50 Pieces/Tube

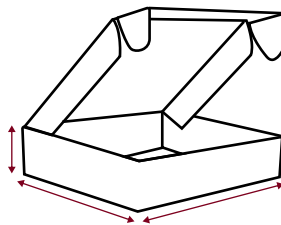

432 Pieces/Inner box

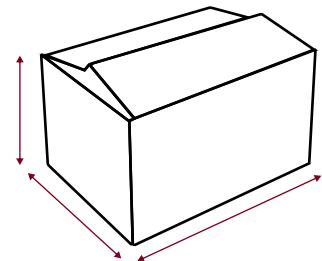

2160 Pieces/Outer box

NOTES & INSTRUCTIONS

- 1.The input voltage shall not exceed the specified range value, otherwise permanent and unrecoverable damage maybe caused;
2. Unless otherwise specified,the parameters in this manual are measured at 25 °C,40%~75% humidity, input nominal voltage and output pure resistance mode under full load;
- 3.All index test methods are based on the company's enterprise standards.
- 4.The copyright and the final interpretation right of the product belong to HENXV.