

HXE-35 SERIES



FEATURES

- Universal AC Input / Full Range
- High Operating Temperature up to 70°C
- Protection: Short Circuit/Overload/Over Voltage
- Cooling by free air convection
- Higher Efficiency / Low Power Dissipation
- 4 Years Warranty

IS 13252 (Part 1) 2010/
IEC 60950-1:2005
R-62006220
www.bis.gov.in



HXE-35 series are designed with lower pole housing and for wide range AC input from 90VAC to 264VAC. In addition to the high Efficiency, Delivering an extremely low no load power consumption. The design of metallic mesh case enhances the heat dissipation. The good performance can be used for Industrial automation & control systems, varied equipments etc.

SELECTION GUIDE

Product model	DC Voltage	Rated Current	Rated Power	Max. Capacitive Load (µF)
HXE-35-05	5V	7A	35W	8000uF
HXE-35-12	12V	3A	36W	1500uF
HXE-35-15	15V	2.4A	36W	1000uF
HXE-35-24	24V	1.5A	36W	750uF
HXE-35-36	36V	1A	36W	470uF
HXE-35-48	48V	0.8A	38.4W	220uF

INPUT CHARACTERISTICS

Parameter	Units	Model
VOLTAGE RANGE	90-264VAC/120-370VDC	
FREQUENCY RANGE	47-63Hz	
AVERAGE EFFICIENCY(115/230VAC)	83%	HXE-35-05
	86%	HXE-35-12
	88%	HXE-35-15
	88%	HXE-35-24
	89%	HXE-35-36
	90%	HXE-35-36
AC CURRENT(Typ.)	0.95A/115VAC	
	0.5A/230VAC	
INRUSH CURRENT(Typ.)	COLD START 25A/115VAC,45A/230VAC	
LEAKAGE CURRENT	<0.75mA/240VAC	

OUTPUT CHARACTERISTICS

Parameter	Units	Model
RIPPLE & NOISE(max.)	80mVp-p	HXE-35-05
	120mVp-p	HXE-35-12
	120mVp-p	HXE-35-15
	150mVp-p	HXE-35-24
	200mVp-p	HXE-35-36
	200mVp-p	HXE-35-48

Parameter	Units	Model
VOLTAGE TOLERANCE	±2.0%	HXE-35-05
	±1.0%	HXE-35-12
	±1.0%	HXE-35-15
	±1.0%	HXE-35-24
	±1.0%	HXE-35-36
	±1.0%	HXE-35-48
LINE REGULATION	±0.5%	
LOAD REGULATION	±1.0%	HXE-35-05
	±0.5%	HXE-35-12
	±0.5%	HXE-35-15
	±0.5%	HXE-35-24
	±0.5%	HXE-35-36
	±0.5%	HXE-35-48
SETUP TIME	1000ms/230VAC at full load	
	2000ms/115VAC at full load	
RISE TIME	30ms/230VAC at full load	
	30ms/115VAC at full load	
HOLD UP TIME (Typ.)	30ms/230VAC at full load	
	12ms/115VAC at full load	

PROTECTION

Parameter	Units
SHORT CIRCUIT	Protection type: Hiccup mode, recovers automatically after fault condition is removed
OVER LOAD	110%-150% Rated Output Power
	Protection type: Hiccup mode, recovers automatically after fault condition is removed
OVER VOLTAGE	5V:4.5~5.5V
	12V:10.6~13.8V
	15V:13.5~18V
	24V:21.6~28.8V
	36V:32.4~39.6V
	48V:43.2~52.8V
	Protection type: Shut down o/p voltage, re-power on to recover

ENVIRONMENT

Parameter	Units
WORKING TEMP	-30°C to +70 °C (Refer to "Derating Curve")
WORKING HUMIDITY	20~90% RH Non-Condensing
STORAGE TEMP, HUMIDITY	~40°C~+85°C, 10~95% RH non-condensing
TEMP COEFFICIENT	±0.03%/°C(0~50°C)
SAFETY PROTECTION	CLASS I
VIBRATION	10~500Hz, 5G 10min./1 cycle,60 min. each along X,Y,Z axes
OVER VOLTAGE CATEGORY	Class III; According to BS EN/EN61558, BS EN/EN50178, altitude up to 2000 meters
MTBF	600K hrs min. MIL-HDBK-217F(25°C)

SAFETY & EMC

Parameter	Units
SAFETY STANDARDS	BS EN/EN62368-1, BS EN/EN60335-1, BS EN/EN61558-1
WITH STAND VOLTAGE	I/P-O/P:4KVAC/min, I/P-PE:2KVAC/min, O/P-FG:1.25KVAC/min
ISOLATION RESISTANCE	I/P-O/P, I/P-FG, O/P-FG:100M Ohms/500VDC/25°C/70%RH
EMC EMISSION	Compliance to BS EN/EN55032(CISPR32)Class B BSEN/EN61000-3-2,-3,ClassA
EMC IMMUNITY	Compliance to BS EN/EN61000-4-2,3,4,5,6,8,perf. CriteriaA BS EN/EN61000-4-11,perf.CriteriaA,BS EN/EN55035

Note

1. All parameters NOT specially mentioned are measured at 115/230VAC input, rated load and 25°C of ambient temperature.
2. Ripple & noise are measured at 20MHz of bandwidth by using a 12" twisted pair-wire terminated with a 0.1uf & 47uf parallel capacitor.
3. Tolerance : includes set up tolerance, line regulation and load regulation.
4. Line regulation is measured from low line to highline at rated load.
5. Load regulation is measured from 0% to 100% rated load.
6. Length of set up time is measured at cold first start. Turning ON/OFF the power supply very quickly may lead to increase of the set up time.
7. The ambient temperature derating of 5°C/1000m is needed for operating altitude greater than 2000m(6500ft).
8. The power supply is considered a component which will be installed into a final equipment. All the EMC tests are been executed by mounting the unit on a 360mm*360mm metal plate with 1mm of thickness. The final equipment must be re-confirmed that it still meets EMC. directives.
9. The out case needs to be connected to the earth, of system when the terminal equipment in operating

DIMENSION, WEIGHT & PACKING

Parameter	Units
Dimesnions	99*82*30mm (LxWxH)
Weight:	230g
Carton Size:	36×32.5×18.5CM
	1417×12.80×7.28in
Master Carton Quantities:	60pcs/Carton

DIMENSIONS AND INSTALLATION

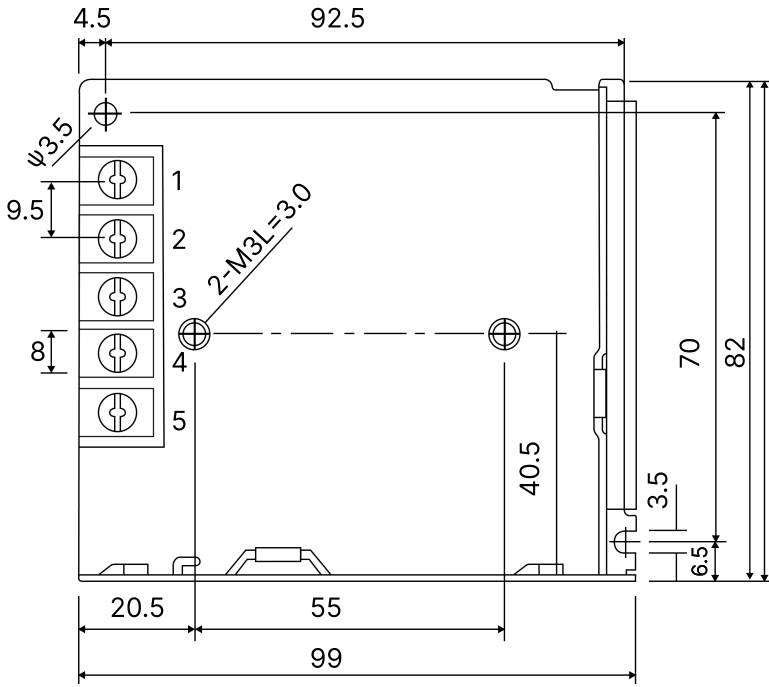

Input

No.	Description
1	AC/L
2	AC/N
3	FG \perp

Output

No.	Description
4	DC OUTPUT-V
5	DC OUTPUT+V

Screw Spec.	L(max)	Torque(max)
M3	5mm	0.4N-m
M3	3mm	0.4N-m

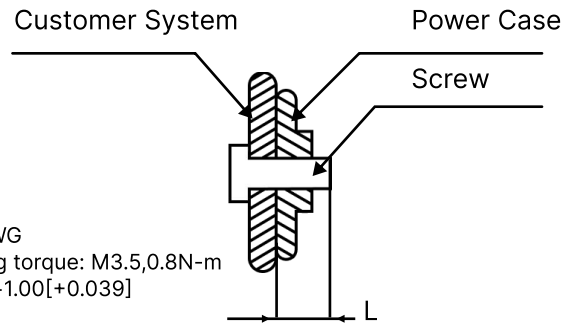
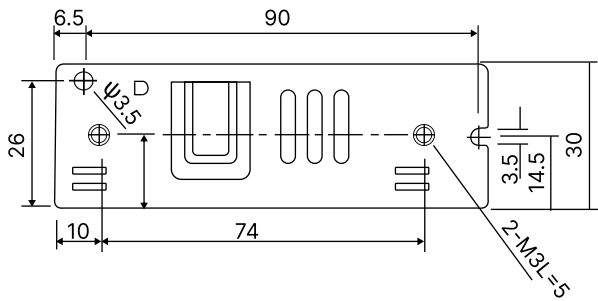

Note: Unit: mm[inc]
Wire range: 22-12AWG
Connector tightening torque: M3.5,0.8N-m
General tolerances:+1.00[+0.039]

BLOCK DIAGRAM

fosc : 115Vac : 75KHz
230Vac : 110KHz

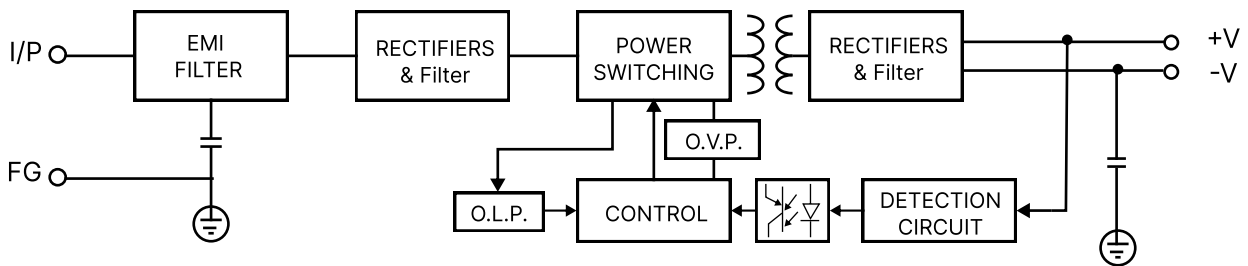

DERATING CURVE

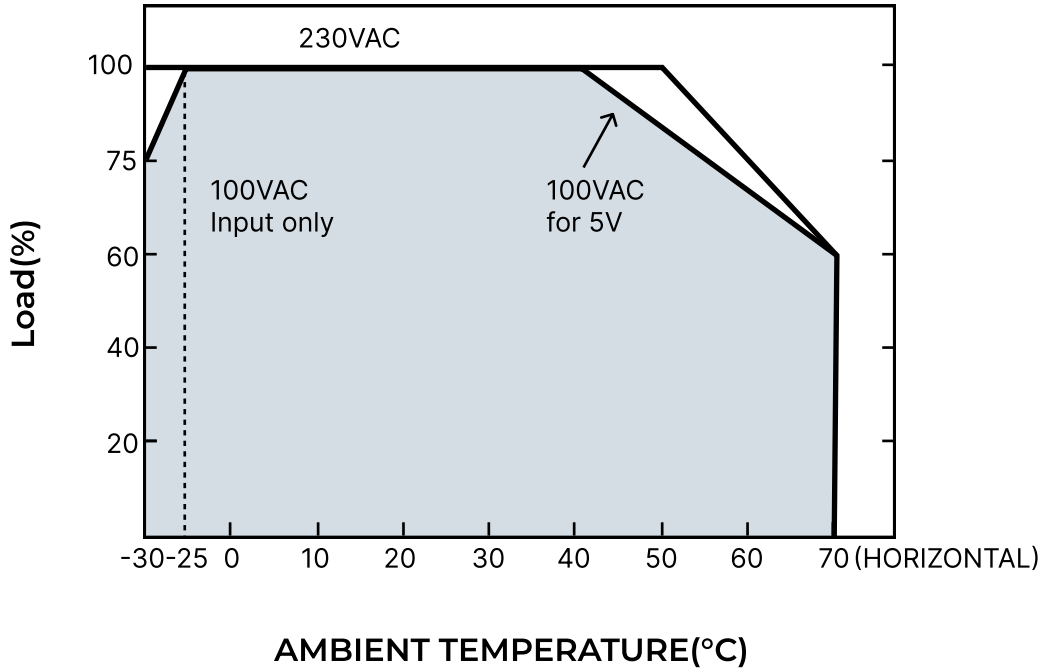

OUTPUT DERATING VS INPUT VOLTAGE CURVES

