

DCK78xx-0.5A Series



CE Report RoHS  WARRANTY

Features

- Wide Operating Temperature Range : -40°C To +85°C
- Up To 95% Efficiency
- No Load Current As Low As 0.2mA
- Ripple As Low As 30mVp-P
- The Pins Are Compatible With The LM78xx Series And Can Be Packaged With Straight Or Curved Pins

Description

Wide Voltage Input, Output 500mA, Non Isolated / Stabilized / Single Output / SIP3 Packaging.

Model Numbering

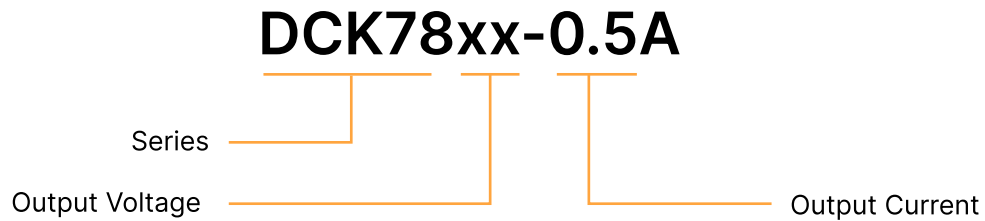

Selection Guide

Product model	Input Voltage Standard Value(range)	Output Voltage	Output Current (mA) (Max./Min.)	Efficiency % (Min./Typ.)	Maximum capacitive load (μ F)
DCK7803 -0.5A	24 (4.75-36)	3.3	500	86/80	680
DCK7805 -0.5A	24 (6.5-36)	5	500	90/83	680
	12 (7-31)	-5	-300	80/81	330
DCK7809 -0.5A	24 (12-36)	9	500	93/90	680
DCK7812 -0.5A	24 (15-36)	12	500	94/91	680
	12 (8-24)	-12	-150	84/85	330
DCK7815 -0.5A	24 (19-36)	15	500	95/93	680
	12 (8-21)	-15	-150	85/87	330

Input Characteristics

Parameter	Conditions	Min.	Typ.	Max.	Units
Input Current (No-Load)	Positive Output	--	5	20	mA
Reflected Ripple Current		3	15	20	mA
Input Filter	Capacitive Filtering				

Remarks: This product does not support hot plug

Output Characteristic

Parameter	Conditions	Min.	Typ.	Max.	Units
Output Voltage Accuracy	Full Load, Input Voltage Range	--	+/-2	+/-4	%
Linear Adjustment Rate	Full Load, Input Voltage Range	--	+/-0.2	+/-0.5	%
Load Regulation Rate	Nominal Input Voltage, 10% To 100% Load	--	+/-0.3	+/-0.6	%
Ripple & Noise	20MHz Bandwidth	--	20	80	mVp-p
Temperature Drift Coefficient	100% Load	--	+/-0.03	--	%/°C
Transient Response Deviation	Nominal Input Voltage, 25% Load Step Change	--	50	245	mV
Transient Recovery Time	Nominal Input Voltage, 25% Load Step Change	--	0.2	1	mS
Short Circuit Protection	Sustainable, Self Restoring				

Note: The testing method for ripple and noise is the parallel line testing method.

General Characteristic

Parameter	Conditions	Min.	Typ.	Max.	Units
Working Temperature	Derated For Use At Temperatures \geq 71 °C (See Figure 1)	-40	--	85	°C
Storage Temperature		-55	--	125	°C
Storage Humidity	No Condensation	--	--	95	%RH
Pin Resistance To Welding Temperature	Welding Point Distance From The Shell 1.5mm, 10 Seconds	--	--	260	°C
Switching Frequency	Full Load, Nominal Input Voltage	550	--	850	kHz
Mean Time Between Failures	MIL-HDBK-217F@25°C	2000	--	--	kHours

Physical Characteristics

Parameter	Contents
Housing Material	Black Flame Retardant And Heat-Resistant Plastic (UL94V-0)
Overall Dimensions	11.60 X 7.55 X 10.16 Mm
Weight	1.8 G(Typ.)
Cooling Mode	Natural Air Cooling

EMC Characteristics

Parameter	Category	Content
EMI	Conductive Disturbance	CISPR32/EN55032 CLASS B (The recommended circuit is shown in Figure 2)
	Radiation Disturbance	CISPR32/EN55032 CLASS B (The recommended circuit is shown in Figure 2)
EMS	Electrostatic Discharge	IEC/EN61000-4-2 Contact $\pm 4\text{KV}$ perf. Criteria B
	Radiated Immunity	IEC/EN 61000-4-3 10V/m perf. Criteria A
	Pulse Group Immunity	IEC/EN 61000-4-4 $\pm 1\text{KV}$ perf. Criteria B
	Surge Immunity	IEC/EN 61000-4-5 line to line $\pm 1\text{KV}$ perf. Criteria B
	Conducted Disturbance Immunity	IEC/EN 61000-4-6 3Vr.m.s perf. Criteria A

Circuit Design and Application

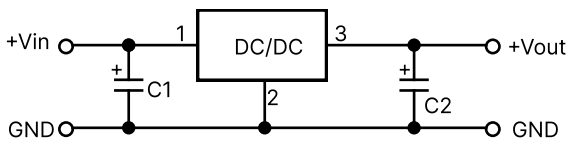

Positive Output

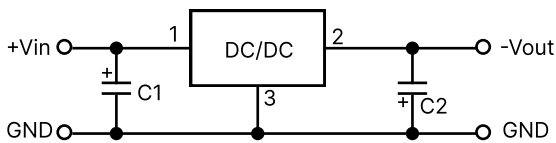

Negative Output

Figure 1: Application circuit

Table 1:
Recommended Capacitive Load Values

Product model	C1/C3	C2/C4
DCK7803 -0.5A	10 μF /50V	22 μF /10V
DCK7805 -0.5A		22 μF /10V
DCK7809 -0.5A		22 μF /16V
DCK7812 -0.5A		22 μF /25V
DCK7815 -0.5A		22 μF /25V

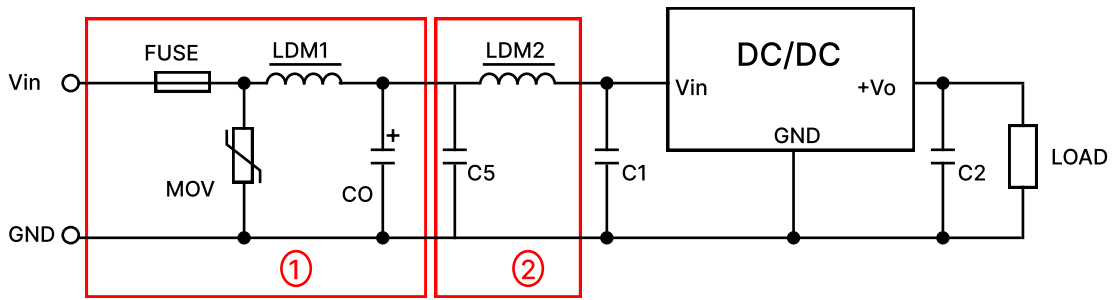

Figure 2: EMC Typical Recommended Circuits

Table 2:
Recommended Circuit Parameter Values

Category	Component	Value
EMI	FUSE	Based on actual selection
	MOV	20D470K
	LDM1	82μH
	C0	270pF/2kV
	C1	Reference Table 2
	C2	
	C5	4.7μF /50V
	LDM2	12μH

1. Typical application: If further reduction of input and output ripple is required, a capacitor filter network can be connected at the input and output ends. The application circuit is shown in Figure 1. However, suitable filter capacitors should be selected. If the capacitance is too large, it may cause overcurrent or poor startup of the power supply. For each output, while ensuring safe and reliable operation, the recommended capacitance load values are shown in Table 1.

2. EMC requirements: For situations with high EMC requirements, a typical EMC recommended circuit is shown in Figure 2.

3. Input requirements: Ensure that the fluctuation range of the input voltage does not exceed the upper and lower limits of the input voltage specified in this data sheet, and the input power must be greater than the output power specified in this data sheet. For situations with a 24V input voltage, it is recommended to connect a TVS tube between the positive and negative input pins for protection (recommended parameters for TVS tubes: 30V, bidirectional, SOD-123 packaging).

4. Output load requirements: Try to avoid using it without load as much as possible; When the actual power of the load is less than 10% of the rated output power in this data sheet, or when it needs to be used in no-load situations, it is recommended to connect a load resistor externally at the output end. The load resistor can be calculated according to 5-10% of the rated power in this data sheet. The calculation formula for the load resistor value is $R_L = U_{out}^2 / (P_{out} * 10\%)$.

5. Overload protection: Under normal working conditions, the output circuit of this product has no protection function for overload situations. The simplest method is to connect a self recovery fuse in series at the input end, or add a circuit breaker outside the circuit; Or during design and selection, the actual power of the circuit should be around 60-80% of the rated power in this data sheet.

Product Characteristic Curve

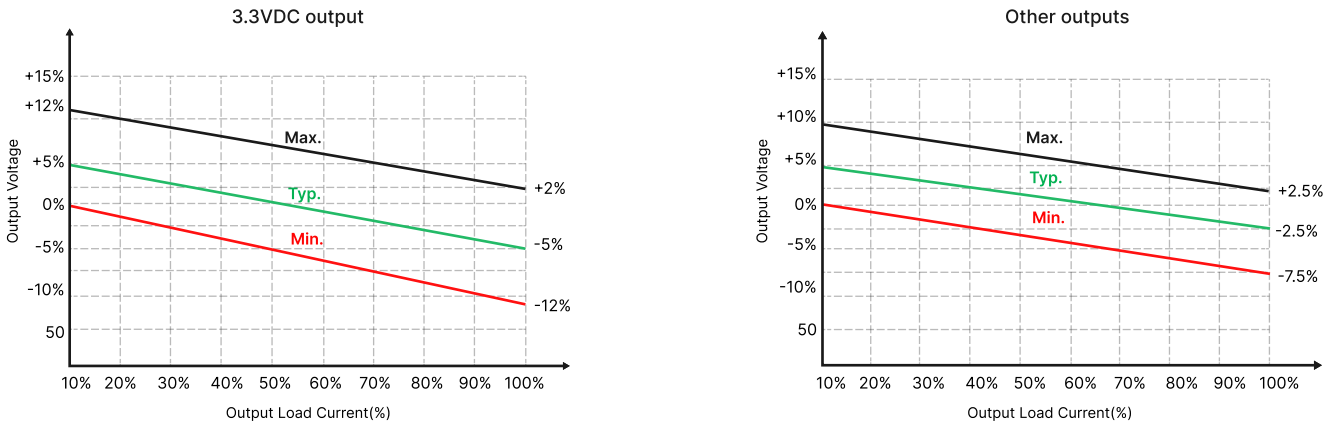

Figure 3: Voltage tolerance envelope

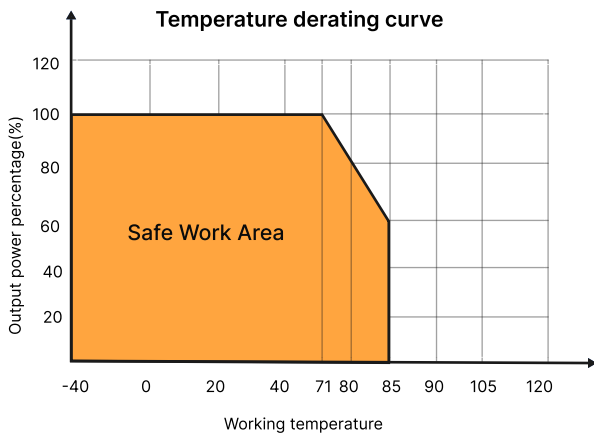

Figure 4: Temperature Derating Curve

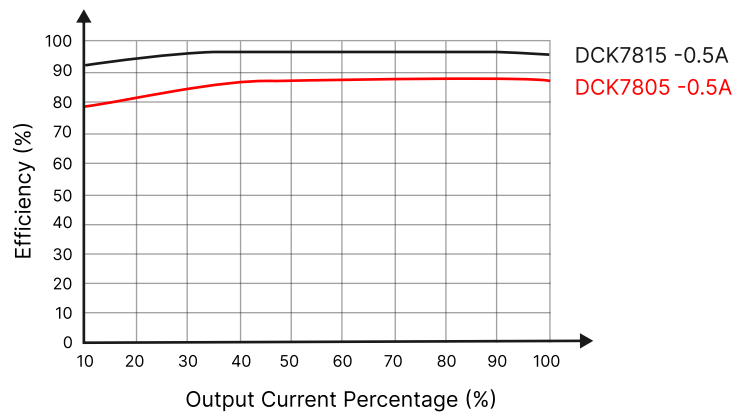

Figure 5: Efficiency Vs Output Load

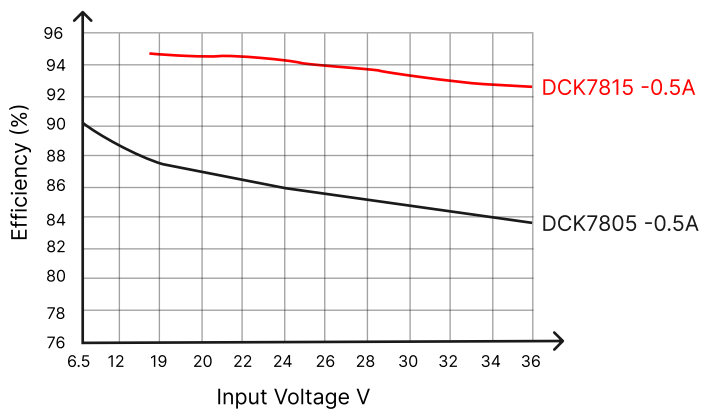

Figure 6: Efficiency Vs Input Voltage

Overall Dimensions and Pin Functions

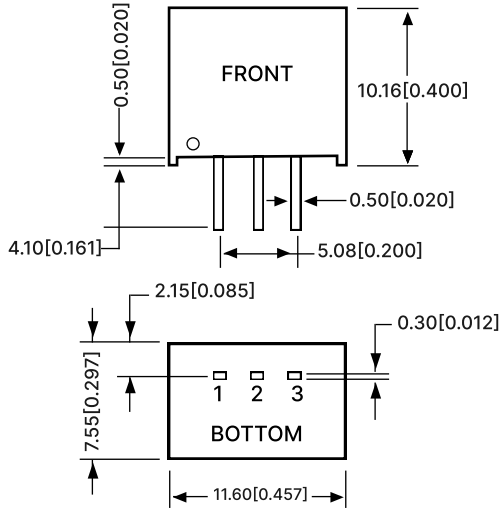

Figure 7: Overall dimensions

Table 3: Pin Function Table

Pin	Positive output	Negative output
1	Vin	Vin
2	GND	-Vo
3	+0V	GND

Note:
Dimensions in mm
Terminal diameter tolerance: +/-0.10
Undeclared tolerance: +/-0.50

Packaging Method

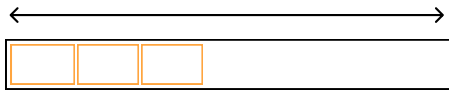

30 Pieces/Tube

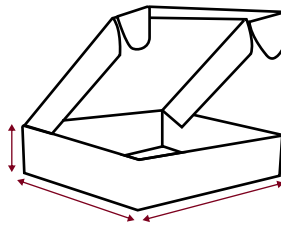

1500 Pieces/Inner box

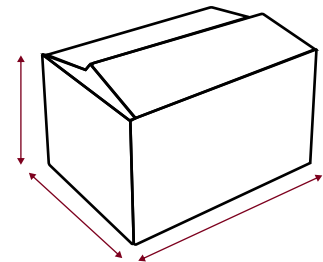

7500 Pieces/Outer box

Notes & Instructions

- 1.The input voltage shall not exceed the specified range value, otherwise permanent and unrecoverable damage maybe caused.
2. Unless otherwise specified, the parameters in this manual are measured at 25 °C,40%~75% humidity, input nominal voltage and output pure resistance mode under full load.
- 3.All index test methods are based on the company's enterprise standards.
- 4.The copyright and the final interpretation right of the product belong to HENXV.