

DCFB_XT-1W Series



Features

- Wide operating temperature range : -40°C To +105°C
- Up to 85% efficiency
- No load current as low as 5mA
- Ripple as low as 30mVp-p
- Sustainable short-circuit protection

Description

DC input, Output 1W, Isolated, Unregulated, Single output, SMD package.

Model Numbering

DCFBxxxxXT-1W



Selection Guide

| Product Model | Input Voltage Standard Value(range) | Output Voltage | Output Current (mA) (Max./Min.) | Efficiency % (Min./Typ.) | Maximum capacitive load (μ F) |
|---------------|--|-------------------|---------------------------------------|-----------------------------|--|
| DCFB0303XT-1W | 3.3VDC (2.97-3.63) | 3.3 | 303 | 75 | 1200 |
| DCFB0305XT-1W | | 5 | 200 | 84 | 1200 |
| DCFB0309XT-1W | | 9 | 111 | 84 | 470 |
| DCFB0312XT-1W | | 12 | 83 | 84 | 220 |
| DCFB0315XT-1W | | 15 | 67 | 84 | 220 |
| DCFB0324XT-1W | | 24 | 42 | 85 | 100 |
| DCFB0503XT-1W | 5VDC (4.5-5.5) | 3.3 | 303 | 75 | 1200 |
| DCFB0505XT-1W | | 5 | 200 | 84 | 1200 |
| DCFB0509XT-1W | | 9 | 111 | 84 | 470 |
| DCFB0512XT-1W | | 12 | 83 | 84 | 220 |
| DCFB0515XT-1W | | 15 | 67 | 84 | 220 |
| DCFB0524XT-1W | | 24 | 42 | 85 | 220 |

| Product Model | Input Voltage Standard Value(range) | Output Voltage | Output Current (mA) (Max./Min.) | Efficiency % (Min./Typ.) | Maximum capacitive load (μ F) |
|---------------|--|-------------------|---------------------------------------|-----------------------------|--|
| DCFB0903XT-1W | 9VDC (8.1-9.9) | 3.3 | 303 | 75 | 1200 |
| DCFB0905XT-1W | | 5 | 200 | 84 | 1200 |
| DCFB0909XT-1W | | 9 | 111 | 84 | 470 |
| DCFB0912XT-1W | | 12 | 83 | 84 | 220 |
| DCFB0915XT-1W | | 15 | 67 | 84 | 220 |
| DCFB0924XT-1W | | 24 | 42 | 85 | 100 |
| DCFB1203XT-1W | 12VDC (10.8-13.2) | 3.3 | 303 | 75 | 1200 |
| DCFB1205XT-1W | | 5 | 200 | 84 | 1200 |
| DCFB1209XT-1W | | 9 | 111 | 84 | 470 |
| DCFB1212XT-1W | | 12 | 83 | 84 | 220 |
| DCFB1215XT-1W | | 15 | 67 | 84 | 220 |
| DCFB1224XT-1W | | 24 | 42 | 85 | 100 |
| DCFB1503XT-1W | 15VDC (13.5-16.5) | 3.3 | 303 | 75 | 1200 |
| DCFB1505XT-1W | | 5 | 200 | 84 | 1200 |
| DCFB1509XT-1W | | 9 | 111 | 84 | 470 |
| DCFB1512XT-1W | | 12 | 83 | 84 | 220 |
| DCFB1515XT-1W | | 15 | 67 | 84 | 220 |
| DCFB1524XT-1W | | 24 | 42 | 85 | 100 |
| DCFB2403XT-1W | 24VDC (21.6-26.4) | 3.3 | 303 | 75 | 1200 |
| DCFB2405XT-1W | | 5 | 200 | 84 | 1200 |
| DCFB2409XT-1W | | 9 | 111 | 84 | 470 |
| DCFB2412XT-1W | | 12 | 83 | 84 | 220 |
| DCFB2415XT-1W | | 15 | 67 | 84 | 220 |
| DCFB2424XT-1W | | 24 | 42 | 85 | 100 |

Input Characteristics

| Parameter | Conditions | Min. | Typ. | Max. | Units | |
|----------------------------|------------------------------|--------------------|------|------|-------|-----|
| Input current (Rated Load) | Nominal voltage input@3.3VDC | 3.3VDC Output | -- | 384 | 405 | mA |
| | | 5VDC Output | -- | 370 | 389 | mA |
| | | 9VDC/12VDC Output | -- | 365 | 389 | mA |
| | | 15VDC/24VDC Output | -- | 350 | 389 | mA |
| | Nominal voltage input@5VDC | 3.3VDC Output | -- | 271 | 286 | mA |
| | | 5VDC Output | -- | 244 | 257 | mA |
| | | 9VDC/12VDC Output | -- | 241 | 254 | mA |
| | | 15VDC/24VDC Output | -- | 241 | 254 | mA |
| | Nominal voltage input@12VDC | 3.3VDC Output | -- | 112 | 118 | mA |
| | | 5VDC Output | -- | 105 | 110 | mA |
| | | 9VDC/12VDC Output | -- | 104 | 110 | mA |
| | | 15VDC/24VDC Output | -- | 103 | 110 | mA |
| | Nominal voltage input@15VDC | 3.3VDC Output | -- | 84 | 89 | mA |
| | | 5VDC Output | -- | 84 | 89 | mA |
| | | 9VDC/12VDC Output | -- | 83 | 89 | mA |
| | | 15VDC/24VDC Output | -- | 83 | 88 | mA |
| | Nominal voltage input@24VDC | 3.3VDC Output | -- | 56 | 61 | mA |
| | | 5VDC Output | -- | 53 | 58 | mA |
| | | 9VDC/12VDC Output | -- | 53 | 58 | mA |
| | | 15VDC/24VDC Output | -- | 52 | 58 | mA |
| Input current (No load) | | -- | 5 | 20 | mA | |
| Reflected ripple current | | 3 | 15 | 20 | mA | |
| Input impulse voltage | 1sec. max. | 3.3VDC/5VDC Input | -0.7 | -- | 9 | VDC |
| | | 9VDC Input | -0.7 | -- | 12 | VDC |
| | | 12VDC Input | -0.7 | -- | 18 | VDC |
| | | 15VDC Input | -0.7 | -- | 21 | VDC |
| | | 24VDC Input | -0.7 | -- | 30 | VDC |
| Input filter | Capacitive filtering | | | | | |

Remarks: This product does not support hot plug

Output Characteristic

| Parameter | Conditions | Min. | Typ. | Max. | Units | |
|-------------------------------|-------------------------------|-------------------------------|---------|------|--------|---|
| Output voltage accuracy | | See Figure 3 (envelope curve) | | | | |
| Linear regulation rate | Input voltage variation +/-1% | 3.3VDC Output | -- | -- | +/-1.5 | % |
| | | Other outputs | -- | -- | +/-1.2 | % |
| Load regulation rate | 10% to 100% load | 3.3VDC Output | -- | 15 | 20 | % |
| | | 5VDC Output | -- | 10 | 15 | % |
| | | 9VDC Output | -- | 8 | 10 | % |
| | | 12VDC Output | -- | 7 | 10 | % |
| | | 15VDC Output | -- | 6 | 10 | % |
| | | 24VDC Output | -- | 5 | 10 | % |
| Ripple & Noise | 20MHz bandwidth | -- | 30 | 100 | mVp-p | |
| Temperature drift coefficient | 100% load | -- | +/-0.03 | -- | %/°C | |
| Short circuit protection | Sustainable, Self-healing | | | | | |

Note: The testing method for ripple and noise is the parallel line testing method.

General Characteristic

| Parameter | Conditions | Min. | Typ. | Max. | Units |
|-----------------------|--|------|------|------|-------|
| Isolation voltage | Input-output, Test time 1 minute, Leakage current less than 1 mA | 1500 | -- | -- | VDC |
| Insulation resistance | Input-output, Insulation voltage 500VDC | 1000 | -- | -- | MΩ |
| Isolation capacitance | Input-output, 100KHz/0.1V | -- | 20 | 50 | pF |
| Working temperature | Temperature ≥ 85°C for derating (See Figure 4) | -40 | -- | +105 | °C |
| Storage temperature | | -55 | -- | +125 | °C |
| Storage humidity | Non condensing | -- | -- | 95 | %RH |

| Parameter | Conditions | Min. | Typ. | Max. | Units |
|---|---|------|------|------|--------|
| Housing temperature rise during operation | Ta=25°C, Nominal Input, Full Output | -- | 15 | 25 | °C |
| Soldering temperature resistance of pins | The distance from the welding spot to the shell is 1.5mm, 10 seconds | -- | -- | 300 | °C |
| | REFLOW: Peak temperature Tc≤245°C, maximum time above 217°C for 60 seconds. | -- | -- | 245 | °C |
| Switching frequency | Full load, Nominal input voltage | -- | 270 | -- | kHz |
| Mean time between failures 【MTBF】 | MIL-HDBK-217F@25°C | 3500 | -- | -- | kHours |

Physical Characteristics

| Parameter | Contents |
|--------------------|--|
| Housing material | Black flame retardant and heat-resistant plastic (UL94V-0) |
| Overall dimensions | 13.30 × 8.5 × 7.25mm |
| Weight | 1.4g(Typ.) |
| Cooling mode | Natural air cooling |

EMC Characteristics

| Parameter | Category | Content |
|-----------|-------------------------|--|
| EMI | Conductive disturbance | CISPR32/EN55032 CLASS B (The recommended circuit is shown in Figure 2) |
| | Radiation disturbance | CISPR32/EN55032 CLASS B (The recommended circuit is shown in Figure 2) |
| EMS | Electrostatic discharge | IEC/EN61000-4-2 Contact ±4KV perf. Criteria B |

Circuit Design and Application

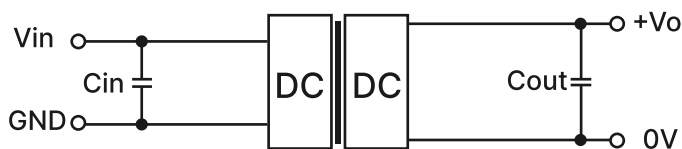

Figure 1: Application circuit

Table 1:
Recommended Capacitive Load Values

| Vin(VDC) | Cin(μF) | Vo(VDC) | Cout(μF) |
|-----------------|---------|-----------------|----------|
| Nominal voltage | 1-10 | Nominal voltage | 2.2-22 |

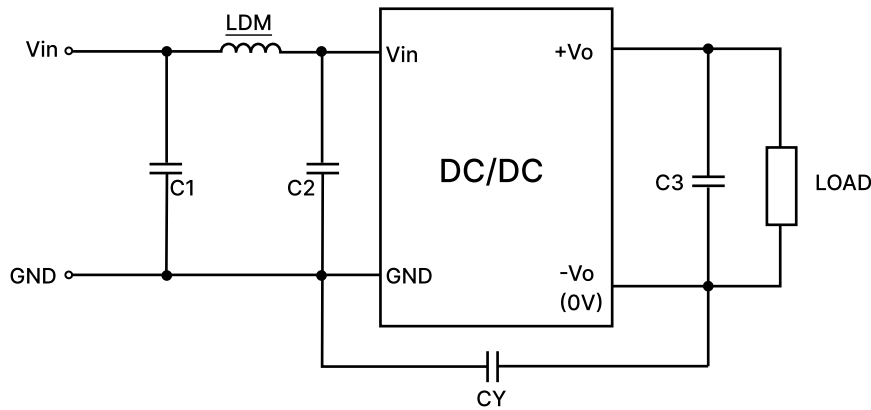

Figure 2: EMC Typical Recommended Circuits

Table 2:
Recommended Circuit Parameter Values

| Category | Component | Value |
|----------|-----------|---------------------|
| EMI | C1 | 4.7 μ F /50V |
| | C2 | 4.7 μ F /50V |
| | C3 | 2.2-22 μ F /50V |
| | CY | 270pF/2kV |
| | LDM | 6.8 μ H |

1. Typical application: If further reduction of input and output ripple is required, a capacitor filter network can be connected at the input and output ends. The application circuit is shown in Figure 1. However, suitable filter capacitors should be selected. If the capacitance is too large, it may cause overcurrent or poor startup of the power supply. For each output, while ensuring safe and reliable operation, the recommended capacitance load values are shown in Table 1.

2. EMC requirements: For situations with high EMC requirements, a typical EMC recommended circuit is shown in Figure 2.

3. Input requirements: Ensure that the fluctuation range of the input voltage does not exceed the upper and lower limits of the input voltage specified in this data sheet, and the input power must be greater than the output power specified in this data sheet. For situations with a 24V input voltage, it is recommended to connect a TVS tube between the positive and negative input pins for protection (recommended parameters for TVS tubes: 30V, bidirectional, SOD-123 packaging).

4. Output load requirements: Try to avoid using it without load as much as possible; When the actual power of the load is less than 10% of the rated output power in this data sheet, or when it needs to be used in no-load situations, it is recommended to connect a load resistor externally at the output end. The load resistor can be calculated according to 5-10% of the rated power in this data sheet. The calculation formula for the load resistor value is $R_L = V_{out}^2 / (P_{out} * 10\%)$.

5. Overload protection: Under normal working conditions, the output circuit of this product has no protection function for overload situations. The simplest method is to connect a self recovery fuse in series at the input end, or add a circuit breaker outside the circuit; Or during design and selection, the actual power of the circuit should be around 60-80% of the rated power in this data sheet.

Product Characteristic Curve

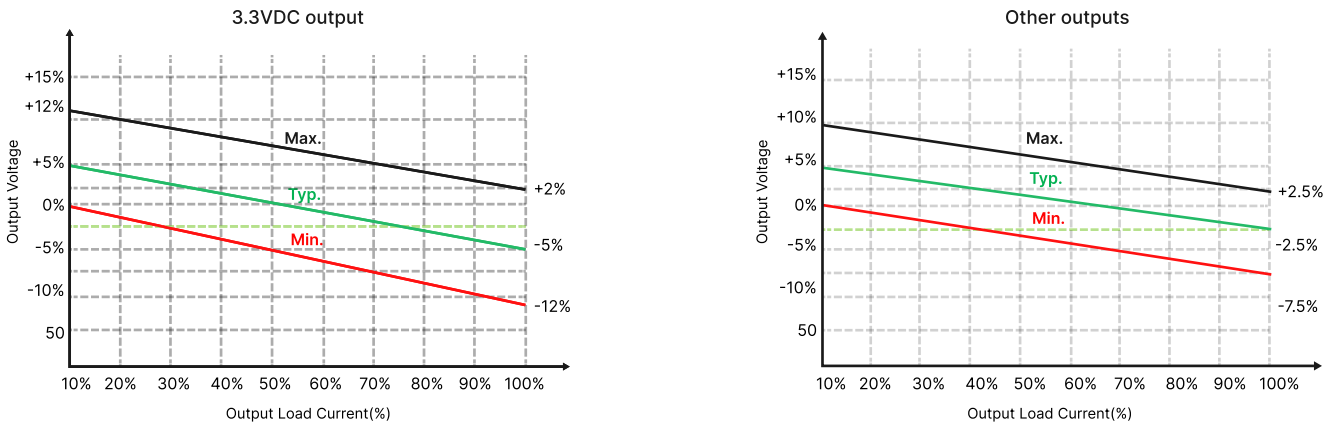

Figure 3: Voltage tolerance envelope

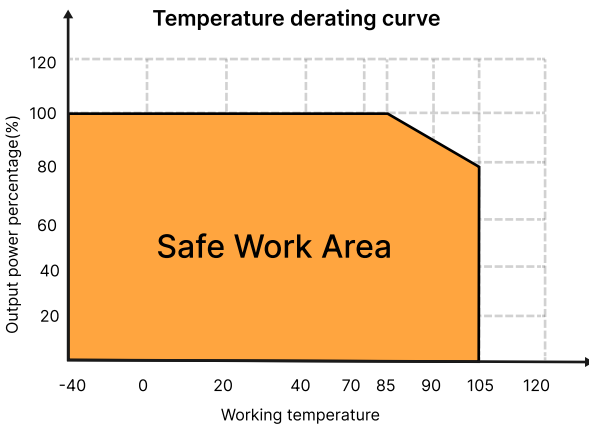

Figure 4: Temperature Derating Curve

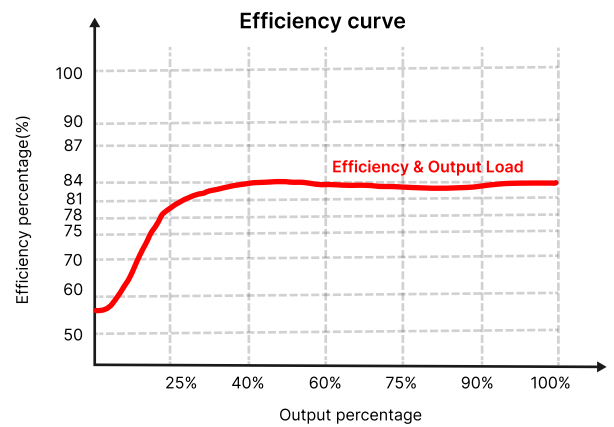

Figure 5: Efficiency Vs Output Load (Nominal Voltage Input)

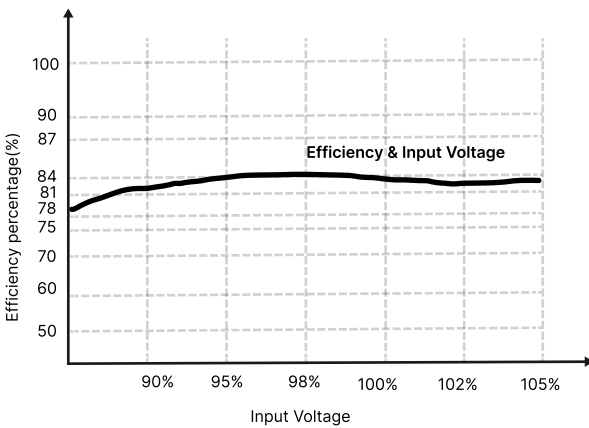
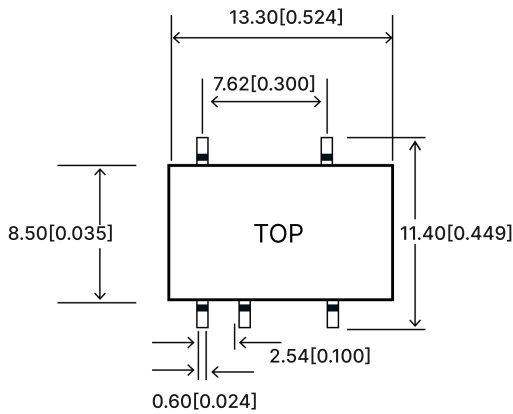

Figure 6: Efficiency Vs Input Voltage (100% Load)

Overall Dimensions and Pin Functions



Note: The grid distance is 2.54mm * 2.54mm

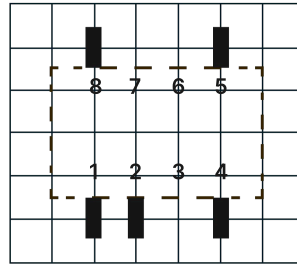
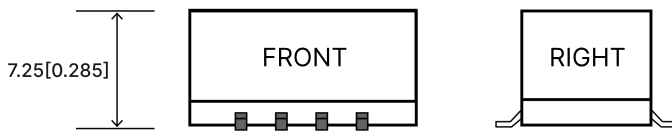

Table 3: Pin Function Table

| Pin | Function |
|-----|----------|
| 1 | GND |
| 2 | Vin |
| 4 | OV |
| 5 | +Vo |
| 8 | NC |



Note:
Dimensions in mm
Terminal diameter tolerance: +/-0.10
Undeclared tolerance: +/-0.50

Figure 7: Overall dimensions

Packaging Method

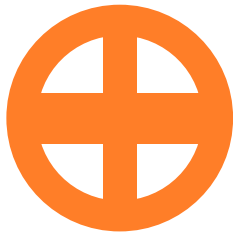

500 Pieces/Reel

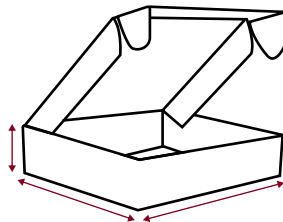

1500 Pieces/Inner box

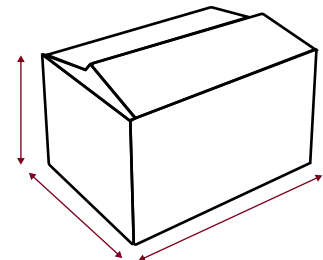

6000 Pieces/Outer box

Notes & Instructions

- 1.The input voltage shall not exceed the specified range value, otherwise permanent and unrecoverable damage maybe caused;
2. Unless otherwise specified,the parameters in this manual are measured at 25 °C,40%~75% humidity, input nominal voltage and output pure resistance mode under full load;
- 3.All index test methods are based on the company's enterprise standards.
- 4.The copyright and the final interpretation right of the product belong to HENXV.