

## HXDT-480W SERIES



## FEATURES

- 3-Phase 340~550VAC Wide Range Input (2-phase operation possible)
- Protection: Short Circuit/Overload /Over Voltage/Over Temperature
- Built-in Constant Current Limiting Circuit
- Full Power Between -30~+60°C
- Built-in Active PFC Function
- DC OK Relay Contact
- High Efficiency 92% and Low Power Dissipation
- 4 Years Warranty
- Works on DC Input (480~780VDC) also

IS 13252 (Part 1) 2010/  
IEC 60950-1:2005  
R-62006220  
www.bis.gov.in



HXDT-480 series are designed with metal housing and for three phase system with wide range from 340VAC To 550VAC. The series offer built-in constant current limiting circuit and active PFC function, and operating in wide temperature range. They are suitable for industrial-related applications such as industrial control, semiconductor fabrication equipment, and factory automation etc.

## SELECTION GUIDE

Product model	DC Voltage	Rated Current	Rated Power
HXDT-480-24	24V	20A	480W
HXDT-480-48	48V	10A	480W

## INPUT CHARACTERISTICS

Parameter	Units	Model
RATED INPUT (Certified Voltage)	Three-Phase 380~ 480VAC (Dual phase operation possible)	
INPUT VOLTAGE RANGE	480 ~ 780VDC	
	340 ~ 550VAC	
FREQUENCY RANGE	47~63Hz	
POWER FACTOR (Typ.)	PF $\geq$ 0.9/400VAC at full load	
	PF $\geq$ 0.88/500VAC at full load	
EFFICIENCY (Typ.)	92.5%	HXDT-480-24
	93.0%	HXDT-480-48
AC CURRENT(Typ.)	0.85A/400VAC	
	0.7A/500VAC	
INRUSH CURRENT(Typ.)	COLD START 50A	
LEAKAGE CURRENT	<3.5mA / 530VAC	

## OUTPUT CHARACTERISTICS

Parameter	Units
RIPPLE & NOISE(MAX.)	150mVp-p
VOLTAGE TOLERANCE	$\pm$ 1.0%
LINE REGULATION	$\pm$ 0.5%
LOAD REGULATION	$\pm$ 1.0%
SETUP,RISE TIME	1200ms, 60ms/400VAC at full load
	800ms, 60ms/500VAC at full load
HOLD UP TIME (Typ.)	20ms / 400VAC at full load
	20ms / 500VAC at full load

## PROTECTION

Parameter	Units	Model
OVER LOAD	105 ~ 130% rated output power.	
	Protection type: Constant current limiting, unit will hiccup after	
	3 sec., re-power on to recover.	
OVER VOLTAGE	24 ~ 28V	HXDT-480-24
	48 ~ 55V	HXDT-480-48
	Protection type : Shut down o/p voltage, auto-recovery after 1 min- sute if the fault condition is removed.	
OVER TEMPERATURE	Shut down o/p voltage, recovers automatically after temperature goes down.	

## ENVIRONMENT

Parameter	Units
WORKING TEMP	-30 ~ +70°C (Refer to "Derating Curve")
WORKING HUMIDITY	20 ~ 95% RH non-condensing
STORAGE TEMP, HUMIDITY	-40 ~ +85°C, 10 ~ 95% RH non-condensing
COLD START	-40°C
TEMP. COEFFICIENT	±0.03%/°C (0 ~ 50°C)
VIBRATION	Component: 10 ~ 500Hz, 2G 10min./1cycle, 60min. each along
	X, Y, Z axes; Mounting clip: Compliance to IEC60068-2-6.
MTBF	1000K hrs min. Telcordia SR-332(Bellcore)

## SAFETY & EMC

Parameter	Units
SAFETY STANDARDS	BS EN/EN61010-1
WITHSTAND VOLTAGE	I/P-O/P:3KVAC I/P-FG:2KVAC O/P-FG:0.5KVAC O/P-DC OK:0.5KVAC
ISOLATION RESISTANCE	I/P-O/P, I/P-FG, O/P-FG:>100M Ohms / 500VDC / 25 / 70% RH
EMC EMISSION	BS EN/EN55032(CISPR32)
EMC IMMUNITY	BS EN/EN61000-4-2, 3, 4, 5, 6, 8

## NOTE

1. All parameters NOT specially mentioned are measured at 400VAC input, rated load and 25°C of ambient temperature
2. Ripple&noise are measured at 20MHz of bandwidth by using a 12" twisted pair-wire terminated with a 0.1uF & 47uF parallel capacitor.
3. Installation clearances: top with 40mm, bottom with 20mm, left and right with 5mm. Increase the space to 10-15mm when the adjacent device is heat source.
4. The ambient temperature derating of 3.5 °C/1000m for operating altitude higher than 2000m(6500ft).
5. The power supply is considered a component which will be installed into a final equipment. The final equipment must be re-confirmed that it still meets EMC directives. For guidance on how to perform these EMC tests, please refer to "EMI testing of component power supplies."

## DIMENSION, WEIGHT & PACKING

Parameter	Units
SIZE:	85.5*129*125mm (LxWxH)
WEIGHT:	1.51kg

**MECHANICAL SPECIFICATION**

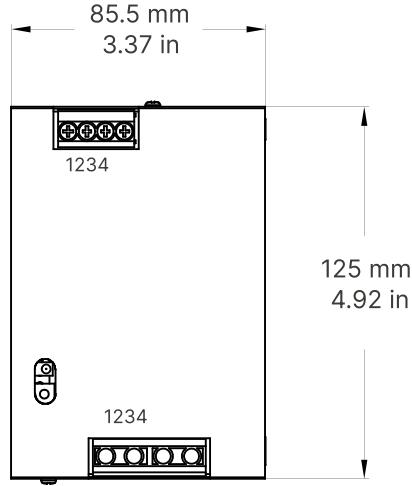
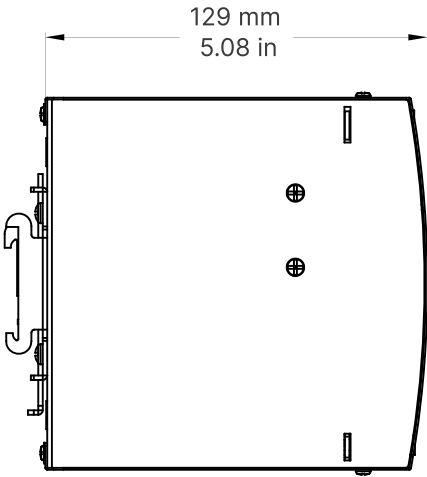

**Input**

No	Description
1	FG $\perp$
2	AC/L3
3	AC/L2
4	AC/L1

**Output**

No	Description
1,2	DC OUTPUT +V
3,4	DC OUTPUT -V

**BLOCK DIAGRAM**

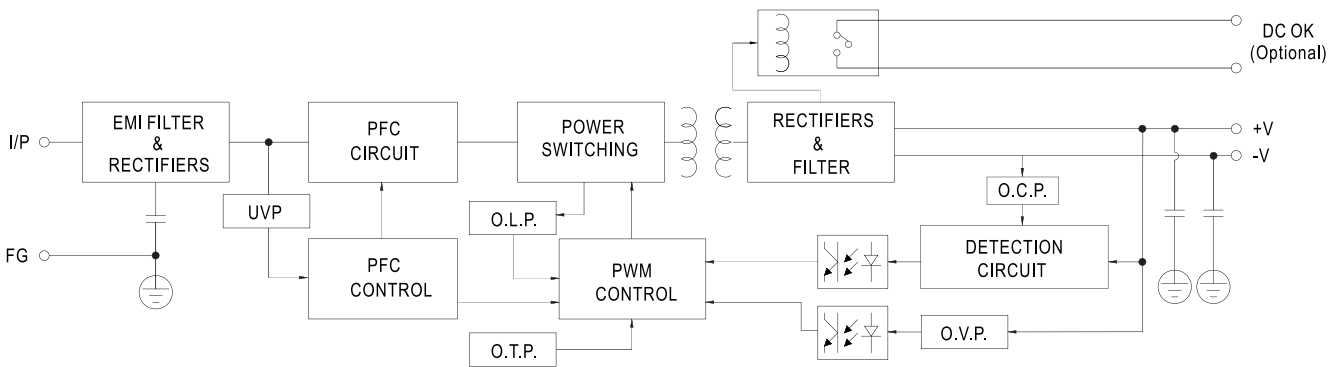

**DC OK RELAY CONTACT**

Parameter	Units
CONTACT CLOSE	PSU turns ON /DC OK
CONTACT OPEN	PSU turns OFF /DC FAIL
CONTACT RATINGS (max)	30V/1A resistive load

Control Pin: DINKLE ECH250R-02P or equivalent (CN25)

Pin No.	Assignment	Mating Housing	Wire Diameter
1,2	DC OK Relay Contact	Dinkle XH-2WAP-20WAP or equivalent (Including in the package)	0.081~0.517mm <sup>2</sup> (20~28AWG)

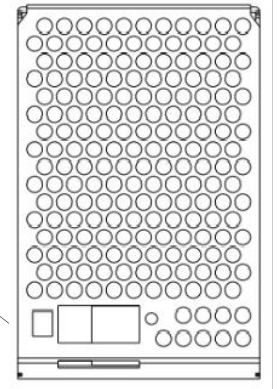

### DERATING CURVE

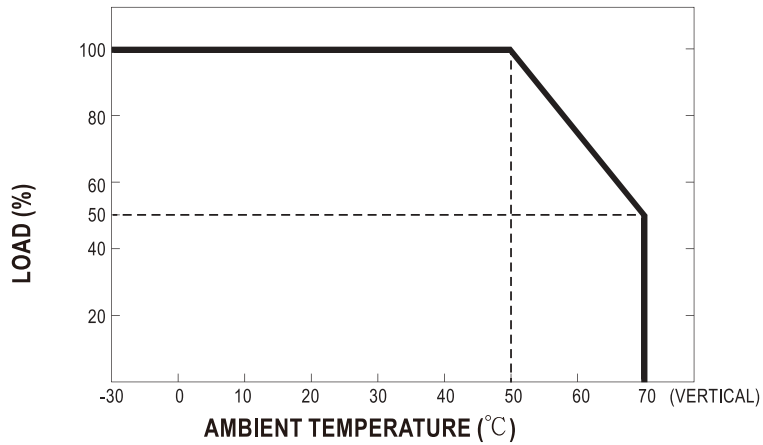

### OUTPUT DERATING VS INPUT VOLTAGE

