

## HXDS-960W SERIES

## FEATURES



- Higher Peak load capability
- Built-in DC Ok Relay Contact
- DC Output Voltage Adjustable
- Current sharing up to 3840W(3+1)
- Built-in Active PFC Function
- 4 Years Warranty
- Works on DC Input (254~370VDC) also

IS 13252 (Part 1) 2010/  
IEC 60950-1:2005  
R-62006220  
www.bis.gov.in



HXDS-960 is a higher performance family of single phase din rail power supplies were designed with metal housing and for full range AC input from 180VAC to 264V AC. With higher efficiency, current sharing up to 3840W(3+1), the entire series have built-in DC OK relay contact and higher peak load capability, they also operate in wide temperature range. The series offer diverse solutions for demanding automation around the world.

## SELECTION GUIDE

Product Model	DC Voltage	Rated Current(max)	Rated Power
HXDS-960-24	24V	40A	960W
HXDS-960-48	48V	20A	960W

## INPUT CHARACTERISTICS

Parameter	Units
RATED INPUT (Certified Voltage)	220 ~ 240VAC
NOMINAL INPUT VOLTAGE RANGE	180 ~ 264VAC, 254 ~ 370VDC
FREQUENCY RANGE	47 ~ 63Hz
POWER FACTOR (Typ)	0.95/230VAC at full load
EFFICIENCY (Typ)	94%
AC CURRENT (Typ)	6A/230VAC
INRUSH CURRENT (Typ)	50A/230VAC cold start
LEAKAGE CURRENT (Typ)	<3.5mA / 240VAC

## OUTPUT CHARACTERISTICS

Parameter	Units	Model
RIPPLE & NOISE(MAX.)	180mVp-p	HXDS-960-24
	250mVp-p	HXDS-960-48
VOLTAGE TOLERANCE	±2.0%	
LINE REGULATION	±0.5%	
LOAD REGULATION	±1.0%	
SETUP, RISE TIME	1000ms, 100ms/230VAC at full load	
HOLD UP TIME (TYP.)	14ms/230VAC at full load	

## PROTECTION

Parameter	Units	Model
OVER LOAD	Normally works within 105 ~ 130% rated output power for more than 3 seconds and then shut down o/p voltage with auto-recovery after 30 seconds if the peak load condition is removed.	
	Constant current limiting within 130 ~ 150% rated output power for more than 3 seconds and then shut down o/p voltage, re-power on to recover.	
OVER VOLTAGE	29 ~ 33V	HXDS-960-24
	56 ~ 65V	HXDS-960-48
	Protection type : Shut down o/p voltage, recovers automatically after temperature goes down	
OVER TEMPERATURE	Protection type : Shut down o/p voltage, recovers automatically after temperature goes down	

## FUNCTION

Parameter	Units
DC OK RELAY CONTACT RATINGS (MAX)	60VDC/0.3A, 30VDC/1A / 30VAC/0.5A resistive load

## ENVIRONMENT

Parameter	Units
WORKING TEMPERATURE	-30°C to 70°C(Refer to "Derating Curve")
WORKING HUMIDITY	20% ~ 95% RH Non-Condensing
STORAGE TEMP/HUMIDITY	-40 ~ +85°C, 10 ~ 95% RH
MTBF	561.17K hrs min. Telcordia SR-332 (Bellcore)
TEMP COEFFICIENT	±0.03%/°C (0 ~ 50°C)
VIBRATION	Component: 10 ~ 500Hz, 2G 10 min / 1cycle, 60min
	each along x,y,z axes; mounting: Compliance to IEC60068-2-6

## SAFETY & EMC

Parameter	Units
SAFETY REGULATIONS	BS EN/EN61010-1
WITHSTAND VOLTAGE	I/P-O/P:3KVAC I/P-FG:2KVAC
	O/P-FG:0.5KVAC O/P-DC OK:0.5KVAC
ISOLATION RESISTANCE	I/P-O/P, I/P-FG, O/P-FG:>100M Ohms / 500VDC / 25°C/ 70% RH
EMC EMISSION	Compliance to BS EN/EN55032 , BS EN/EN61000-3-2,-3
EMC IMMUNITY	Compliance to BS EN/EN61000-4-2,3,4,5,6,8,11, BS EN/EN55024,
	BS EN/EN61000-6-2 (BS EN/EN50082-2)

## NOTE

1. All parameters NOT specially mentioned at 230VAC input, rated load and 25°C of ambient temperature.
2. Ripple & noise are measured from peak to peak with band width limit of 20MHz(0.1uF and 47uF/50V parallel capacitor under DC output full load, AC nominal input 25°C ambient temperature).
3. Installation clearances: top with 40mm, bottom with 20mm, left and right with 5mm. Increase the space to 10-15mm when the adjacent device is heat source.
4. It could hold up 3 seconds max when reached peak power 1248W, and the average output power should not exceed the rate power.
5. Derating may be needed under low input voltage. Please check the derating curve for more details.
6. The ambient temperature derating of 3.5 °C/1000m for operating altitude higher than 2000m(6500ft).

## DIMENSIONS, WEIGHT & PACKING

Parameter	Units
SIZE:	150*110*125.2 mm (LxWxH)
WEIGHT:	2.47kg
CARTON SIZE:	49 × 34.5 × 16.5 CM
	19.29 × 13.58 × 6.50 in
MASTER CARTON QUANTITIES:	6pcs / Carton

**MECHANICAL SPECIFICATION**

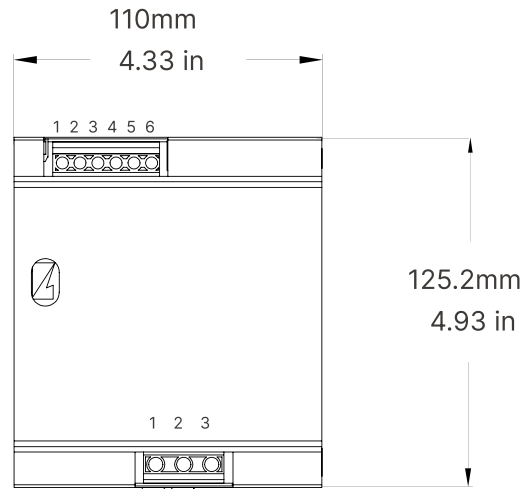
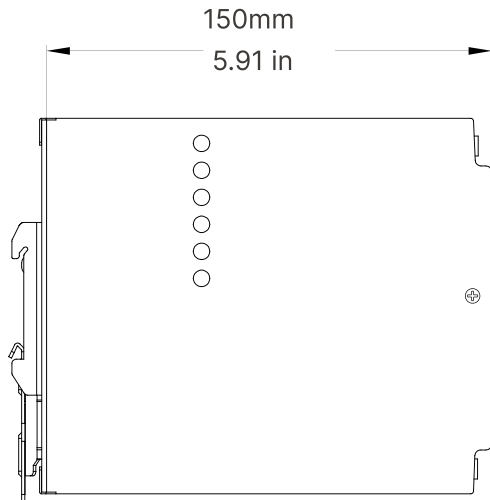

Input

No	Description
1	FG $\perp$
2	AC/N
3	AC/L

Output

No	Description
1,2,3	DC OUTPUT +V
4,5,6	DC OUTPUT -V

**BLOCK DIAGRAM**

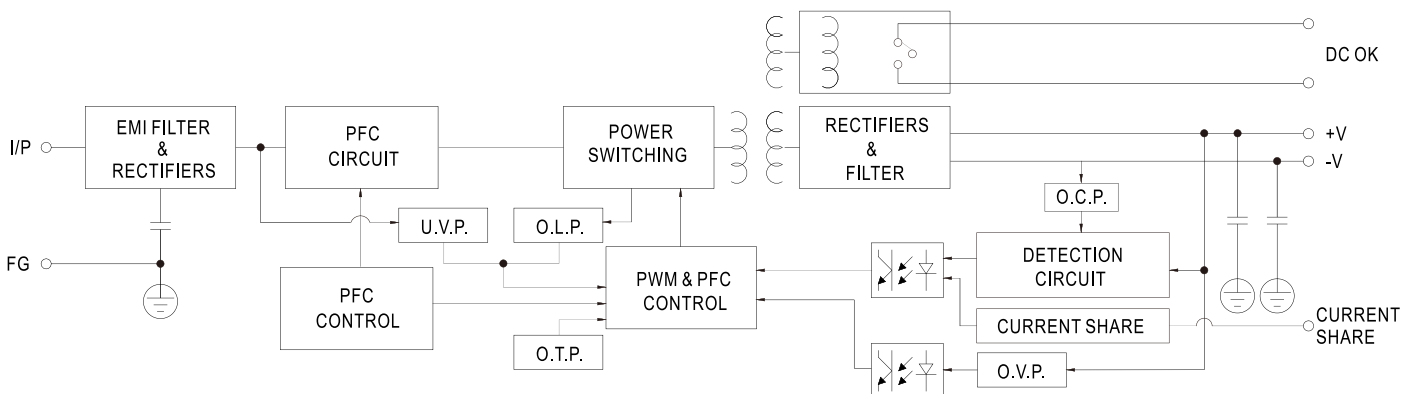

**DC OK RELAY CONTACT**

Parameter	Units
Contact Close	PSU turns on / DC OK
Contact Open	PSU turns off / DC Fail
Contact Ratings (max.)	30V/1A resistive load

**PEAK LOADING**

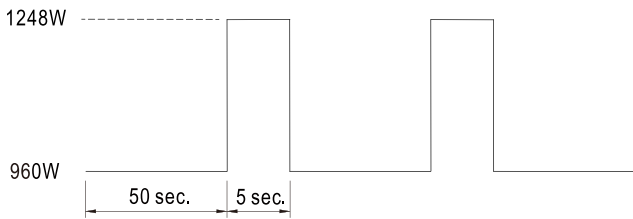

Full Load

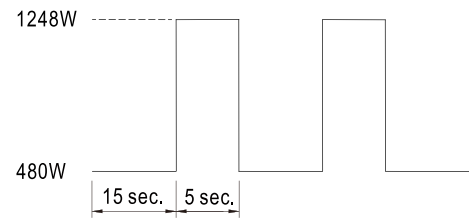

Half Load

**DERATING CURVE**

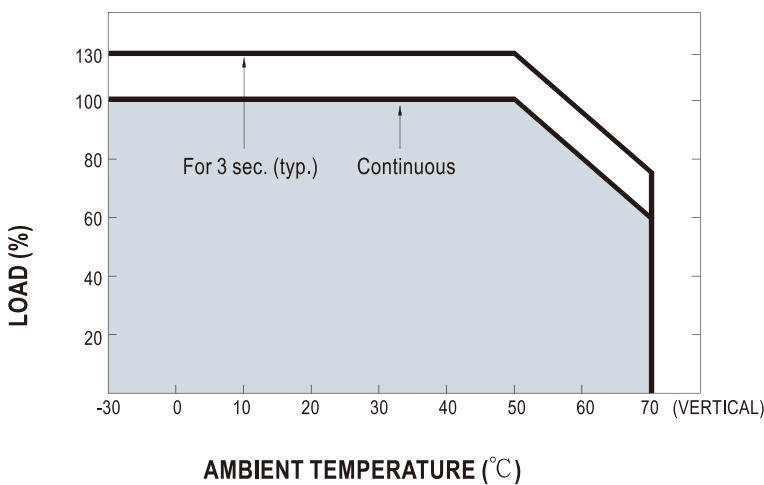

**OUTPUT DERATING VS INPUT VOLTAGE**

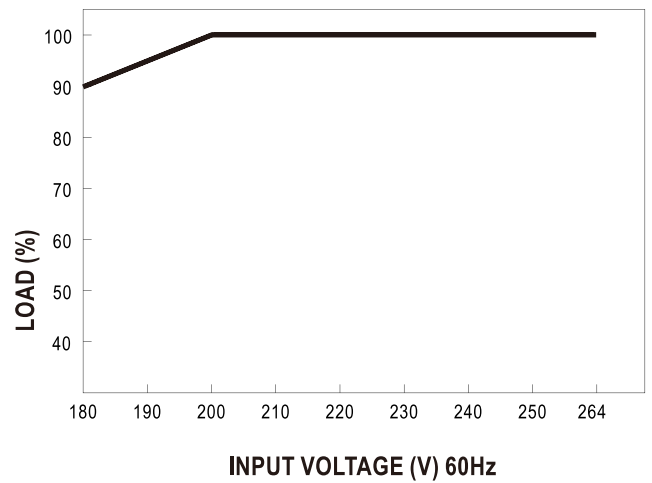

**NOTE**

Current Sharing

1. Connection type of parallel operation is as follows (P+,P- parallel connection)
2. The output voltage difference between the parallel units should be less than 0.2V
3. The total output current must not exceed the value calculated of the following equation  
(Output current at parallel operation)=(The rated current per unit)\* (Number of unit) x 0.9
4. The maximum quantity of parallel operation is eight units, If need more quantity of parallel operation, please contact the manufacture.
5. In parallel connection, the minimum output load should be more than 3% of total output load  
(Min. load > 3% rated current per unit x number of unit)

