

HXDH-30W SERIES

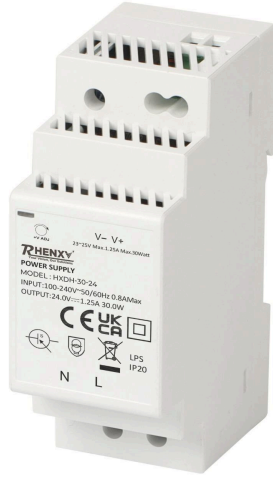

FEATURES

- Isolation Class II
- Ultra Slim Step Shape
- Protection: Short Circuit / Overload / Over Voltage
- Class 2/Pass LPS
- DC Output Voltage Adjustable
- Over Voltage Category II
- 4 Years Warranty
- Works on DC Input (120~370VDC) also

IS 13252 (Part 1) 2010/
IEC 60950-1:2005
§
R-62006220
www.bis.gov.in



HXDH-30W step shape power family are designed with ultra-slim plastic housing and for full range AC input from 90VAC To 264VAC. The series are isolation Class II Level, achieving high efficiency and low no-load power consumption. They provide adjustable DC output voltage and operate in wide temperature range. The good performance can be used for building automation, household and industrial control systems etc.

SELECTION GUIDE

Product Model	DC Voltage	Rated Current	Rated Power
HXDH-30-05	5V	3A	15W
HXDH-30-12	12V	2A	24W
HXDH-30-15	15V	2A	30W
HXDH-30-24	24V	1.5A	36W
HXDH-30-48	48V	0.75A	36W

INPUT CHARACTERISTICS

Parameter	Units	Model
VOLTAGE RANGE	90 ~ 264VAC	
	120 ~ 370VDC	
FREQUENCY RANGE	47~63Hz	
AC CURRENT(Typ.)	0.88A/115VAC	
	0.48A/230VAC	
INRUSH CURRENT(Typ.)	COLD START 25A/115VAC 45A/230VAC	
EFFICIENCY	82%	HXDH-30-05
	88%	HXDH-30-12
	89%	HXDH-30-15
	89%	HXDH-30-24
	92%	HXDH-30-48

OUTPUT CHARACTERISTICS

Parameter	Units	Model
RIPPLE & NOISE(MAX.)	80mVp-p	HXDH-30-05
	120mVp-p	HXDH-30-12
	120mVp-p	HXDH-30-15
	150mVp-p	HXDH-30-24
	240mVp-p	HXDH-30-48
VOLTAGE ADJ. RANGE	4.5~5.5V	HXDH-30-05
	10.8~13.8V	HXDH-30-12
	13.5~18V	HXDH-30-15
	21.6~29V	HXDH-30-24
	43.2~55.2V	HXDH-30-48

Parameter	Units	Model
VOLTAGE TOLERANCE	±2.0%	HXDH-30-05
	±2.0%	HXDH-30-12
	±2.0%	HXDH-30-15
	±2.0%	HXDH-30-24
	±2.0%	HXDH-30-48
LINE REGULATION	±1.0%	
LOAD REGULATION	±1.0%	
SETUP, RISE TIME	500ms, 50ms/230VAC at full load	
	500ms, 50ms/115VAC at full load	
HOLD UP TIME (Typ.)	30ms/230VAC at full load	
	12ms/115VAC at full load	

PROTECTION

Parameter	Units	Model
OVER LOAD	105 ~ 160% rated output power	
	Hiccup mode when output voltage <50%, recovers automatically after fault condition is removed	
	Constant current limiting within 50%-100% rated output voltage, recovers automatically after fault condition is removed.	
OVER VOLTAGE	5.75 ~ 7.5V	HXDH-30-05
	15 ~ 18V	HXDH-30-12
	18.8 ~ 22.5V	HXDH-30-15
	30 ~ 36V	HXDH-30-24
	57.6~ 67.2V	HXDH-30-48
	Protection type : Shut off o/p voltage, clamping by zener diode	

ENVIRONMENT

Parameter	Units
WORKING TEMP	-20°C ~+70°C
WORKING HUMIDITY	20 ~ 90% RH Non-Condensing
STORAGE TEMP, HUMIDITY	-40°C ~+85°C, 10 ~ 95% RH non-condensing
TEMP. COEFFICIENT	±0.03%/°C(0 ~ 50°C) RH non-condensing
VIBRATION	10 ~ 500Hz, 2G 10min./1cycle, period for 60min. each along X, Y, Z axes; Mounting: Compliance to IEC60068-2-6
OPERATING ALTITUDE	5000 meters
OVER VOLTAGE CATEGORY	Class II; According to EN62368-1;altitude up to 2000 meters

SAFETY & EMC

Parameter	Units
SAFETY STANDARDS	BS EN/EN62368-1
WITHSTAND VOLTAGE	I/P-O/P:4KVAC
ISOLATION RESISTANCE	I/P-O/P:100M Ohms / 500VDC / 25°C / 70% RH
EMC EMISSION	BS EN/EN 55032 class B, BS EN/EN IEC 61000-3-2,3
EMC IMMUNITY	BS EN/EN61000-4-2,3,4,5,6,8,11

NOTE

1. All parameters NOT specially mentioned at 230VAC input, rated load and 25°C of ambient temperature.
2. Ripple & noise are measured from peak to peak with band width limit of 20MHz(0.1uF and 47uF/50V parallel capacitor under DC output full load, AC nominal input 25°C ambient temperature).
3. Installation clearances: top with 40mm, bottom with 20mm, left and right with 5mm. Increase the space to 10-15mm when the adjacent device is heat source.
4. Derating may be needed under low input voltage. Please check the derating curve for more details.
5. Efficiency test after 30 minutes of burn-in.
6. The ambient temperature derating of 3.5 °C/1000m for operating altitude higher than 2000m(6500ft).

DIMENSION, WEIGHT & PACKING

Parameter	Units
SIZE:	35*90*58 mm (LxWxH)
WEIGHT:	120g
CARTON SIZE:	37 × 22 × 25 CM
	14.57 × 8.66 × 9.84 in
MASTER CARTON QUANTITIES:	50pcs / Carton

MECHANICAL SPECIFICATION

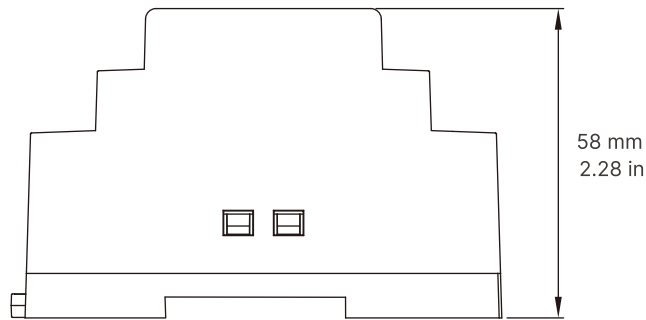
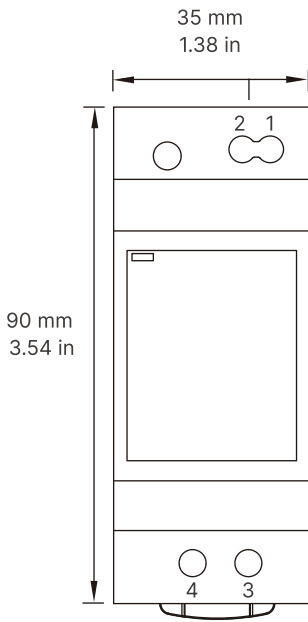

Input

No	Description
3	AC/L
4	AC/N

Output

No	Description
1	+V
2	-V

FUNCTIONAL DIAGRAM

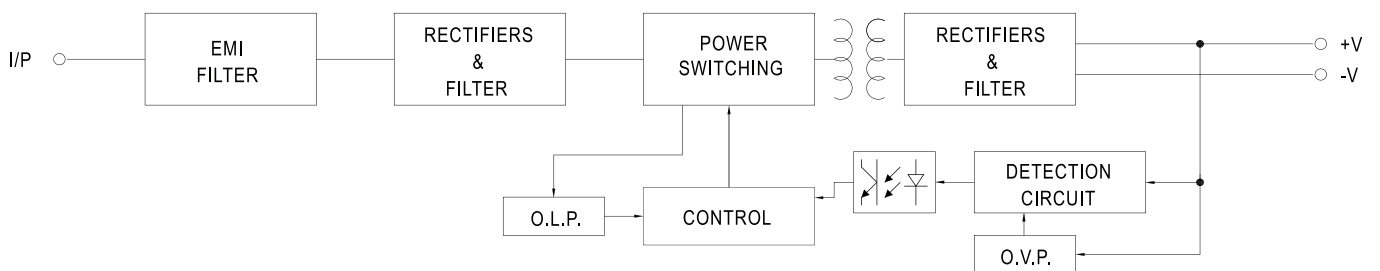

DERATING CURVE

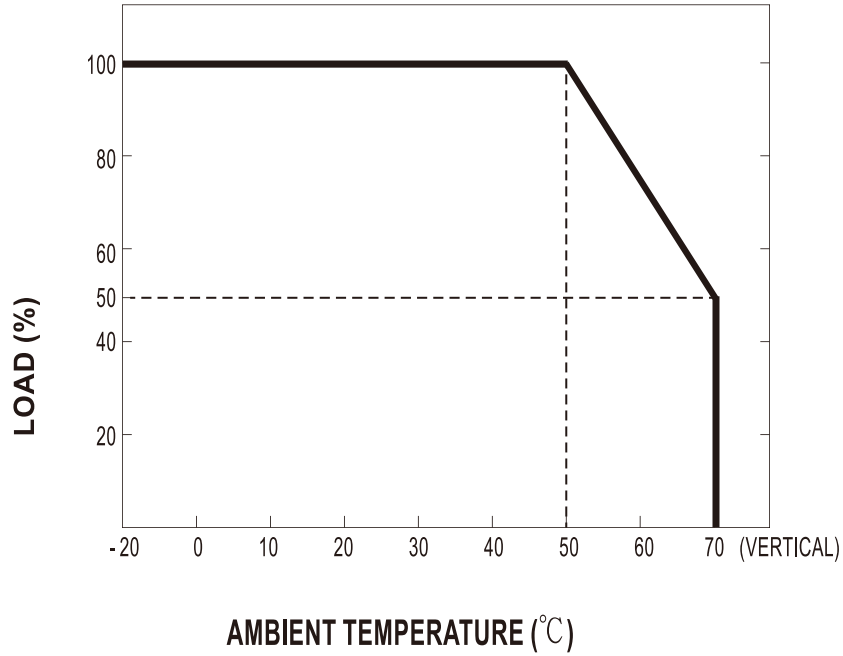

OUTPUT DERATING VS INPUT VOLTAGE CURVES

